

**nifty**

# SD170 (SD50)

Operating & Safety Instructions  
**MODEL SD170 (SD50) SERIES**

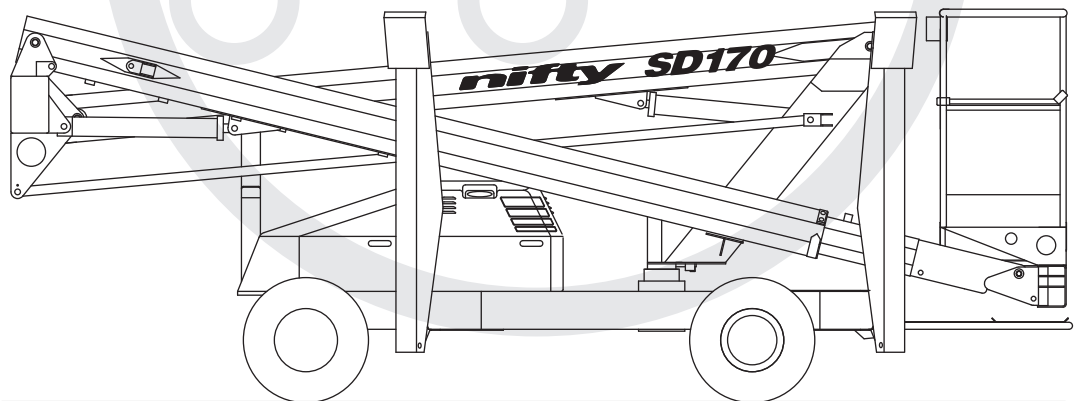

Manufactured by:  
**Niftylift Limited**  
Fingle Drive  
Stonebridge  
Milton Keynes  
MK13 0ER  
England

[www.niftylift.com](http://www.niftylift.com)  
e-mail: [info@niftylift.com](mailto:info@niftylift.com)  
Tel: +44 (0)1908 223456  
Fax: +44 (0)1908 312733



**niftylift.com**  
info@niftylift.com

M50161/07





# Table of Contents

<b>1</b>	<b>INTRODUCTION AND GENERAL INFORMATION</b>	<b>PAGE</b>
1.1	Foreword	2
1.2	Scope	3
1.3	Introducing the SD170 Self Drive (SD) Series	3
1.4	General Specification	4
1.5	Identification	5-6
1.6	EC Declaration of Conformity	7
<b>2</b>	<b>SAFETY</b>	
2.1	Mandatory Precautions	8-11
2.2	Environmental Limitations	11
2.3	Noise & Vibration	11
2.4	Test Report	12
<b>3</b>	<b>PREPARATION AND INSPECTION</b>	
3.1	Unpacking	13
3.2	Preparation for Use	13
3.3	Pre-Operational Safety Check Schedules	14-15
3.4	Placard, Decals and Installation	16-19
3.5	Torque Requirements	20
<b>4</b>	<b>OPERATION</b>	
4.1	Control Circuit Components	21-23
4.2	Setting up Procedures	24
4.3	Ground Control Operation	25-26
4.4	Platform Control Operation	27-30
4.5	Cage Weigh System	31-33
4.6	Driving Controls	34
4.7	Batteries and Charging	35-36
4.8	Transporting, Towing, Craneage, Storage and Setting to Work	37-40
<b>5</b>	<b>EMERGENCY CONTROLS</b>	
5.1	General	41
5.2	Emergency Procedures - Incapacitated Operator	41
5.3	Emergency Procedures - Machine Failure	41
5.4	Incident Notification	41
5.5	Outrigger Recovery	42-44
<b>6</b>	<b>RESPONSIBILITIES</b>	
6.1	Changes in Ownership	45
6.2	Manual of Responsibilities	45
6.3	Inspection/Service/Pre-Hire Check List	46-47

# 1 Introduction and General Information

## 1.1 FOREWORD

The purpose of these manuals is to provide the customer with proper safety operating and maintenance instructions essential for proper machine operation.

All information in these manuals should be **READ** and fully **UNDERSTOOD** before any attempt is made to operate the machine. **THESE MANUALS ARE VERY IMPORTANT TOOLS** - Keep them with the machine at all times.

**The manufacturer has no direct control over machine application and use, therefore conformance with good safety practices is the responsibility of the user and his operating personnel.**

**All information in these manuals is based on the use of the machine under proper operating conditions. Alteration and/or modification of the machine are strictly forbidden.**

**One of the most important facts to remember is that any equipment is only as safe as those who operate it.**

### **DANGER, WARNING, CAUTION, IMPORTANT, INSTRUCTIONS AND NOTICE**

Any place these topics may appear, either in this manual or on the machine, they are defined as follows:

**DANGER:** If not correctly followed there is a high probability of serious injury or death to personnel.

**WARNING OR CAUTION:** If not correctly followed there is some possibility of serious injury or death to personnel.



THE **'SAFETY ALERT'** SYMBOL IS USED TO CALL ATTENTION TO POTENTIAL HAZARDS WHICH MAY LEAD TO SERIOUS INJURY OR DEATH, IF IGNORED.

**IMPORTANT AND INSTRUCTIONS:** Denotes procedures essential to safe operation and prevention of damage to or destruction of the machine.

**NOTICE:** Indicates general safety rules and/or procedures relating to the machine.

**It is the owner's/user's responsibility to know and comply with all applicable rules, regulations, laws, codes and any other requirements applicable to the safe use of this equipment.**

## 1.2 SCOPE

These operating instructions contain all the necessary information required to allow the safe operation of Niftylift SD170 (SD50), powered by electric (DC), diesel or petrol (gasoline) engine, or a combination of these.

For further technical information, circuit diagrams and specific instructions for all maintenance which may need to be carried out by specialist trained personnel, see the associated Workshop and Parts manual for your model of machine.

## 1.3 INTRODUCING THE SD170 (SD50) SELF DRIVE SERIES

Please note at the time of going to press all information, illustrations, details and descriptions contained herein are valid. Niftylift reserves the right to change, alter, modify or improve its products without any obligations to install them on previously manufactured machines.

If you require further information after reading this manual, please do not hesitate to contact us at your nearest office.

**Niftylift Ltd, Fingle Drive, Stonebridge, Milton Keynes MK13 0ER, Great Britain**

**Tel: (011 44) 1908 223456 Fax: (011 44) 1908 312733**

**Niftylift Inc, 32 Concourse Way, Greer, SC 29651 USA**

**Tel: +01 864 968 8881 Fax: +01 864 968 8836**

**Nifty Pty Ltd, 11 Kennington Drive, Tomago, NSW 2322, Australia**

**Tel: +61 (0) 2 4964 9765 Fax: +61 (0) 2 4964 9714**

The Niftylift SD (Self Drive) is a range of extremely versatile articulating boom mounted via a 360° powered swing mechanism. Driven from the platform, the Niftylift SD170 (SD50) Self Drive accommodates up to two men and their equipment, and offers a working height of up to 17m (56ft) or an outreach of 8.7m (28ft 5in) with a maximum capacity of 200kg (440lb) or 500lb for USA models.

High traction tyres and hydraulic wheel motors give 25% gradeability for 2WD versions or 30% for 4WD models with the option of slow or fast drive speed. Automatic braking and audible alarms activated by tilt sensor help to prevent the operator from working on unsafe terrain. The outriggers make a swift set up possible and minimise the weight of the machine. A unique pressure sensitive micro switch system fitted to each outrigger prevents operation of the machine until all outriggers have been correctly deployed and also provides a loud audible alarm warning of a possible hazardous situation

A simple, all-hydraulic proportional control system gives smooth, reliable movement of the platform and maximum reliability in the harshest environments.

The Niftylift Self Drive provides a fast, safe, cost effective method of access, both inside and out, for a multitude of applications where overhead working is required.

*Models Include the Following:-*

E: - D.C. ELECTRIC

BE: - BI-ENERGY (DIESEL & BATTERY)

D: - DIESEL

PE: - PETROL & BATTERY

P: - PETROL

**Operating & Safety Instructions****1.4 GENERAL SPECIFICATION**

<b>FEATURE</b>	<b>SD170</b>
MAXIMUM HEIGHT - WORKING	17.10m 56ft 1in
MAXIMUM HEIGHT - PLATFORM	15.10m 49ft 6in
MAXIMUM HEIGHT - STOWED	2.10m 6ft 11in
MAXIMUM OUTREACH	8.70m 26ft 6in
MAXIMUM WIDTH	1.60m 5ft 3in
MAXIMUM LENGTH - STOWED	5.60m 18ft 4in
MAXIMUM CAPACITY	200kg 440lb
TURRET ROTATION	355°
TURRET TAILSWING	Zero
PLATFORM SIZE - LENGTH x WIDTH	0.65m x 1.1m 25in x 44in
CONTROLS	Full proportional hydraulic
HYDRAULIC PRESSURE	200bar
GRADEABILITY	25%
TRAVEL SPEEDS	Fast: 3mph (4.83kph) Slow: 1.2mph (1.93kph)
GROUND CLEARANCE	100mm 4in
GROSS VEHICLE WEIGHT	2250kg 4950lb
MAXIMUM GROUND PRESSURE	0.049kN/cm <sup>2</sup> 10210lb/ft <sup>2</sup>
POWER OPTIONS	E (Electric) models - 4 x 6v 250 AH batteries P (G) (Petrol/Gasoline) models - Honda Engine D (Diesel) models - Kubota 722 (4WD) Kubota OC95 (2WD)
SD170 4WD version: Outriggers become electric over hydraulic controls, Gradeability 30%, Gross Vehicle Weight 2450kg (Bi-Energy), Maximum Ground Pressure 0.055kN/cm <sup>2</sup> 11430lb/ft <sup>2</sup>	

## 1.5 IDENTIFICATION (UK PLATE)

			
NIFTYLIFT LTD. FINGLE DRIVE, STONEBRIDGE MILTON KEYNES MK13 0ER ENGLAND TEL 01908 223456 : FAX 01908 312733 e-mail : info@niftylift.com			
SERIAL No			
TYPE			
YEAR OF MANUFACTURE			
WEIGHT			kg
RATED LOAD	PERSONS	+	kg
MAXIMUM SAFE WORKING LOAD			kg
MAXIMUM PULL			N
MAXIMUM WIND SPEED			m/s
MAX. ALLOWABLE INCLINATION			Deg.
MAXIMUM HYDRAULIC PRESSURE			bar
MAXIMUM VOLTAGE			V
AMPS			A
ELEC. CCT D	ISSUE		
HYD. CCT D	ISSUE		
			P10805

**This manufacturer's plate is attached to Boom 1 on each machine at the time of manufacture on every Niftylift. Please ensure all sections have been stamped and are legible.**

**1.5a IDENTIFICATION (USA PLATE)**

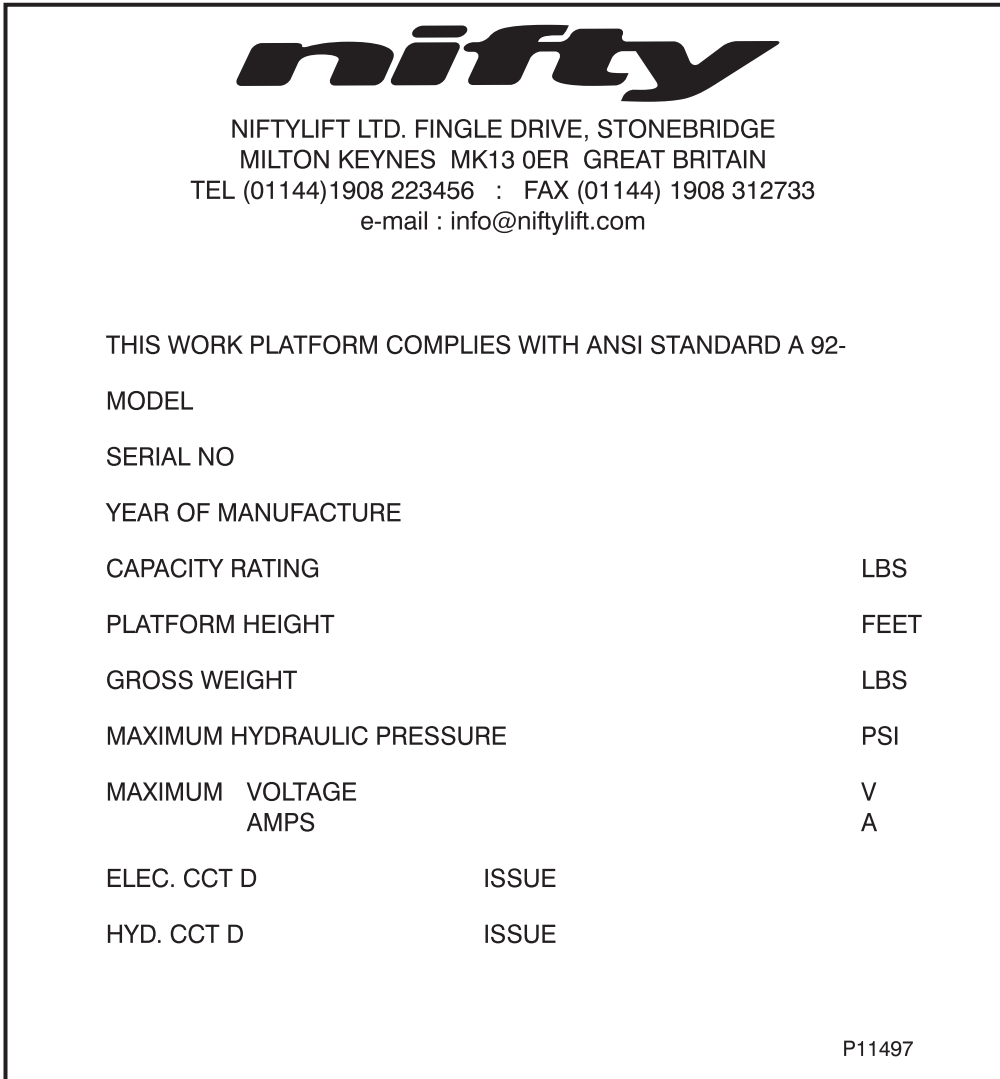

**This manufacturer's plate is attached to Boom 1 on each machine at the time of manufacture on every Niftylift. Please ensure all sections have been stamped and are legible.**



## 1.6 EC DECLARATION OF CONFORMITY (Typical)



---

---

**EC DECLARATION OF CONFORMITY**

---

---

MANUFACTURER AND PERSON RESPONSIBLE FOR DOCUMENTATION:	<b>NIFTYLIFT LTD MALCOLM NORTH</b>
ADDRESS:	<b>FINGLE DRIVE, STONEBRIDGE, MILTON KEYNES, MK13 0ER, ENGLAND.</b>
MACHINE TYPE:	MOBILE ELEVATING WORK PLATFORM
MODEL TYPE:	
SERIAL NUMBER:	
NOTIFIED BODY:	RWTUV Anlagentechnik GmbH
NOTIFIED BODY NUMBER:	0044
ADDRESS:	POSTFACH 10 32 61 D-45141 ESSEN GERMANY
CERTIFICATE NUMBER:	
APPLICABLE STANDARDS:	EN 280:2001+A2:2009 DIN EN 60204-1, 2006/42/EC

*We hereby declare that the above mentioned machine conforms with the requirements of the Machinery Directive, 2006/42/EC and EMC Directive 2004/108/EC*

SIGNED: 

DATE: 14<sup>th</sup> December 2009

NAME: Malcolm North

POSITION: Engineering Manager

**NOTE:**

THIS DECLARATION CONFORMS WITH THE REQUIREMENTS OF ANNEX II-1.A OF THE COUNCIL DIRECTIVE 2006/42/EC. ANY MODIFICATIONS TO THE ABOVE MENTIONED MACHINE WILL INVALIDATE THIS DECLARATION, AND THE MACHINE'S APPROVAL.

## **2 Safety**

### **2.1 MANDATORY PRECAUTIONS**

When operating your Niftylift, your safety is of utmost concern. In order to fully appreciate all aspects of the machines operation it should be ensured that each operator has **READ** and fully **UNDERSTOOD** the relevant manual covering machine use, maintenance and servicing. If any doubts exist concerning any points covered in your manual, contact your local dealer or Niftylift Ltd.

Before using any Niftylift, thoroughly inspect the machine for damage or deformation to all major components. Likewise, check the control systems for hydraulic leaks, damaged hoses, cable faults or loose covers to electrical components. At no time should damaged or faulty equipment be used - Correct all defects before putting the platform to work. If in doubt, contact your local dealer or Niftylift Ltd (see front cover for address).



**THE MANUFACTURER HAS NO DIRECT CONTROL OVER THE MACHINE APPLICATION AND USE. THEREFORE CONFORMATION WITH GOOD SAFETY PRACTICES IS THE RESPONSIBILITY OF THE USER AND HIS OPERATING PERSONNEL. FAILURE TO UNDERSTAND AND FOLLOW ALL SAFETY RULES COULD RESULT IN SERIOUS INJURY OR DEATH.**

- 2.1.1** Only persons trained on the same or a similar model will be permitted to operate the aerial Niftylift.
- 2.1.2** Always operate the Niftylift in full accordance with the manufacturers Operating & Safety Instructions for that model.
- 2.1.3** Before use each day and at the beginning of each shift the Niftylift shall be given a visual inspection and functional test including, but not limited to, operating and emergency controls, safety devices, personal protective clothing, including fall protection, air, hydraulic and fuel system leaks, cables and wiring harness, loose or missing parts, tyres and wheels, placards, warnings, control markings and Operating and Safety Manuals, guards and guard rail systems and all other items specified by the manufacturer.
- 2.1.4** Any problems or malfunctions that affect operational safety must be repaired prior to use of the platform, with specific regard to any safety components refer to the Parts Manual for part numbers and details. If in doubt, contact Niftylift Ltd (Details on page 3). **Ensure wheels are chocked before carrying out any maintenance that involves brake release as described in Section 4.8.2 – Towing.**
- 2.1.5** Always ensure that all warning labels, instructions, placards, control markings and Safety Manuals are intact and clearly legible. If replacements are required contact your local dealer or Niftylift. Always observe and obey safety and operating instructions on such labels.
- 2.1.6** Do not alter, modify or disable in any way the controls, safety devices, interlocks or any other part of the machine.
- 2.1.7** Before the Niftylift is used and during use the user shall check the area in which it is to be used for possible hazards such as, but not limited to, uneven ground drop-offs, holes, bumps, obstructions, debris, floor and overhead obstructions, high voltage conductors, wind and weather, unauthorised persons and any other possibly hazardous conditions.
- 2.1.8** Never exceed the maximum platform capacity, as indicated on the decals and machine serial plate.

- 2.1.9** Only operate the Niftylift on a firm, level surface.
- 2.1.10** Never position any part of the Niftylift within 4.0m, (12ft) of any electrical power line, conductor or similar not exceeding 66kV. (Minimum span 125m) Other distances for increased voltages and different spans are given in NZECP 34:1993

**THIS MACHINE IS NOT INSULATED.**

If in doubt, contact the appropriate authorities

- 2.1.11** On entering the platform, ensure that the drop down entry bar is closed afterwards.
- 2.1.12** Use of an approved safety belt and lanyard, hard hat and appropriate safety clothing is mandatory. Fasten harness to designated harness securing points within the platform and do not remove until leaving the platform whilst in the stowed position.

**2.1.13**

Always remain standing within the platform. Do not attempt to increase your height or reach by standing and/or climbing on the platform guard rails or any other object. **KEEP YOUR FEET ON THE PLATFORM FLOOR.** Do not sit, stand or climb on the guard rail, mid rail or boom linkage. Use of planks, ladders or any other devices on the Niftylift for achieving additional height or reach shall be prohibited.

- 2.1.14** Do not use the platform levelling system to artificially increase the outreach of the platform. Never use boards or ladders in the platform to achieve the same result.
- 2.1.15** Do not use the platform to lift overhanging or bulky items which may exceed the maximum capacity or carry objects which may increase the wind loading on the platform.
- 2.1.16** The Niftylift shall not be operated from a position on trucks, trailers, railway cars, floating vessels, scaffolds or similar equipment unless the application is approved in writing by Niftylift Ltd in Great Britain.
- 2.1.17** Before lowering or slewing, always check below and around the platform to ensure that the area is clear of personnel and obstructions. Care should be taken when slewing out into areas where there may be passing traffic. Use barriers to control traffic flow or prevent access to the machine.
- 2.1.18** Stunt driving and horseplay, on or around the Niftylift, shall not be permitted.
- 2.1.19** When other moving equipment and vehicles are present, special precautions shall be taken to comply with local ordinances or safety standards established for the work place. Warnings such as, but not limited to flags, roped off areas, flashing lights and barricades shall be used.
- 2.1.20** Before and during driving while the platform is elevated the operator shall maintain a clear view of the path of travel, maintain a safe distance from obstacles, debris, drop offs, holes, depressions, ramps and other hazards to ensure safe elevated travel. Maintain a safe distance from overhead obstacles.
- 2.1.21** Under all travel conditions the operator shall limit travel speed according to conditions of ground surface, congestion, visibility, slope, location of personnel and other factors causing hazards of collision or injury to personnel.

### **Operating & Safety Instructions**

- 2.1.22** The aerial platform shall not be driven on grades, side slopes or ramps exceeding those for which the aerial platform is rated by the manufacturer.
- 2.1.23** It shall be the responsibility of the user to determine the hazard classification of any particular atmosphere or location. Aerial platforms operated in hazardous locations shall be approved and suitable for the duty. (See ANSI/NFPA 505-1987 where applicable).
- 2.1.24** The operator shall immediately report to his supervisor any potentially hazardous location(s) (environment) which become evident during operation.
- 2.1.25** If an operator encounters any suspected malfunction of the Niftylift or any hazard or potentially unsafe condition relating to capacity, intended use or safe operation, he shall cease operation of the Niftylift and request further information as to safe operation from his management, or owner, dealer or manufacturer before further operation of the Niftylift.
- 2.1.26** The operator shall immediately report to his superior any problems or malfunctions of the Niftylift, which becomes evident during operation. Any problems or malfunctions that affect the safety of operation shall be repaired prior to continued use.
- 2.1.27** The boom and platform of the Niftylift shall not be used to jack the wheels off the ground.
- 2.1.28** The Niftylift shall not be used as a crane.
- 2.1.29** The Niftylift shall not be positioned against another object to steady the platform.
- 2.1.30** Care should be taken to prevent rope, electric cords and hoses from becoming entangled in the aerial platform.
- 2.1.31** Batteries shall be recharged in a well ventilated area free of flame, sparks or other hazards which may cause explosion. Highly explosive hydrogen gas is produced during the charging process.
- 2.1.32** When checking electrolyte levels great care should be taken to protect eyes, skin and clothing. Battery acid is highly corrosive and protective glasses and clothing is recommended.
- 2.1.33** If the platform or elevating assembly becomes caught, snagged or otherwise prevented from normal motion by adjacent structure or other obstacles, such that control reversal does not free the platform, all personnel shall be removed from the platform safely before attempts are made to free the platform using ground controls.
- 2.1.34**



When the machine is not in use always stow the booms correctly. **NEVER LEAVE THE KEYS IN THE MACHINE**, if it is to be left for any period of time. Use wheel chocks if leaving on an incline.

- 2.1.35** The engine must be shut down while fuel tanks are being filled. Fuelling must be done in a well ventilated area free of flame, sparks or any other hazard which may cause fire or explosion. **PETROL (GASOLINE), LIQUID PROPANE AND DIESEL FUELS ARE FLAMMABLE.**

**2.1.36**

**NEVER START THE NIFTYLIFT IF YOU SMELL PETROL (GASOLINE), LIQUID PROPANE OR DIESEL FUEL. THESE FUELS ARE HIGHLY FLAMMABLE**

**2.1.37**

The operator shall implement means provided to protect against use by unauthorised persons.

**2.1.38**

Never remove anything that may affect the stability of the machine such as, but not limited to, batteries, covers, engines, tyres or ballast.

## **2.2 ENVIRONMENTAL LIMITATIONS**

All Niftylift Self Drives are limited to operation as previously described. Unless specifically configured otherwise, the machine will have short time rating for operation in extreme temperatures, i.e. reduced battery cycle times for low temperatures, e.g. freezers, food storage etc, cooling limitations for high temperatures, i.e. oil temperature not to exceed -23 to 93° Celsius.

Extended operation in dusty environments is not recommended, frequent cleaning will be necessary. All dust, dirt, salt encrustation, excess oil or grease should be removed. Deposits of paint or bitumen, particularly on legends or labels should be removed.

All standard Niftylift machines are rated for a wind speed of 12.5 m/s, which equates to 45kph / 28mph or force 6 on the Beaufort scale. No attempt should be made to operate a Niftylift in wind strengths above this limit and if the operator has any doubts over the wind speed he / she should cease operation immediately until it can be established that the wind speed has fallen to a safe level.

## **2.3 NOISE AND VIBRATION**

The airborne noise emission on the SD170 range of machines does not exceed 79dB(A), measured at a perpendicular distance of 4m, under equivalent continuous A-weighted sound pressure test conditions. This was based on a Diesel powered machine, working on high throttle, and under load. All other models will exhibit significantly lower emissions than this figure, dependant on power option.

In normal operation the Vibration level to which the operator is subjected will not exceed a weighted root mean square acceleration value of 2.5 m/s<sup>2</sup>.

## **2.4 TEST REPORT**

All Niftylift machine models are subjected to a comprehensive 'type test' which duplicates all combinations of safe working load (SWL), overload, windage, inertia and pull force to assess the various safe stability criteria. Self propelled machines are also subjected to kerb and braking tests at the SWL to satisfy additional 'worse case' stability requirements.

Each individual machine is then subjected to static overload tests on flat level ground with 150% of the SWL, exceeding the requirements of EN280 for power operated MEWPs. Self propelled machines are also tested at the maximum working angle **plus** 0.5° with a test load of 125% of the SWL. Finally, on all machines, a functional test is performed with 110% of SWL.

All safety devices are checked for correct operation, operating speeds are checked against benchmark figures and the dynamic functions ensure that all acceleration and deceleration forces are within acceptable limits. All noted defects are rectified and recorded before the machine is permitted to enter into service.

## 3 Preparation and Inspection

### 3.1 UNPACKING

Since the manufacturer has no direct control over the shipping or carriage of any Niftylift it is the responsibility of the dealer and/or owner and/or leaser to ensure the Niftylift has not been damaged in transit and a Pre-operational Report has been carried out by a qualified engineer before the aerial platform is put into service.

- A) Remove all ropes, straps and or chains used to secure the aerial platform during transit.
- B) Ensure any ramp, loading dock or fork lift used is capable of supporting or lifting the aerial platform.
- C) If the aerial platform is to be driven off, please ensure that the operator has read and fully understood this entire manual. Refer to the appropriate section for precise operating instructions.

**\*\*\*Carry out the Inspection/service/pre-hire check list (see pages 44 & 45) before placing machine in service.**

### 3.2 PREPARATION FOR USE

Whilst every effort has been made at the Niftylift factory to ensure your machine arrives in a safe and operable condition it is necessary to carry out a systematic inspection prior to putting the aerial platform into service.



**THIS IS NOT A REQUEST IT IS MANDATORY**

To assist the user in this task you will find enclosed a Inspection/service/pre-hire check list, which must be filled out upon delivery/receipt of the machine.

Before the user carries out the Pre-operational Report he must have read and fully understood all the contents of the Operating, Safety and Maintenance Manual.



**WARNING - FAILURE TO COMPLETE THE INITIAL PRE-OPERATIONAL REPORT AND RETURN THE TOP COPY TO NIFTYLIFT RENDERS THE WARRANTY INVALID.**

**WARNING - DO NOT OPERATE A POTENTIALLY DEFECTIVE OR MALFUNCTIONING MACHINE. CORRECT AND REPAIR ANY DEFECTS BEFORE OPERATING YOUR NIFTYLIFT.**

### **3.3 PRE-OPERATIONAL SAFETY CHECK SCHEDULES**

Before use at the beginning of the work shift, the aerial platform shall be given a visual inspection and functional tests including, but not limited to the following. It is recommended that these be performed at regular intervals as indicated on each checklist.

#### **3.3.1 DAILY SAFETY CHECKS**

- 1) Check that all labels (decals) are in place and legible.
- 2) Visually inspect the machine for damaged or loose components.
- 3) Check that batteries are charged i.e. Charger has a solid green light and a pulsing red light.
- 4) Check the fuel level (if applicable).
- 5) Check that canopies/covers and guards are in place and secure.
- 6) Check that the boom rest switch is operable (if applicable).
- 7) Check that control levers are secure and operate freely.
- 8) Check that operating buttons and emergency stop buttons function properly.
- 9) Check the operation of the manual hand pump.
- 10) Visually inspect all hydraulic hoses and fittings for damage or leaks.
- 11) Check operation of the stabiliser alarm.
- 12) Check that outrigger footpads are secure.
- 13) Check that the platform pivot pins and their tag bolts are secure.
- 14) Check security and operation of the boom clamp.
- 15) Check that the tilt alarm is functioning properly (On a slope of 5° or more the alarm should sound and drive should be disabled).
- 16) Check the operation of the cage weigh system (If fitted). See section 4.5.3 for testing and verification procedure.

#### **3.3.2 WEEKLY SAFETY CHECKS**

- 1) Inspect tyres and wheels for damage and wear.
- 2) Check tyres for correct pressure. 30psi (2.1 bar)
- 3) Check battery fluid levels and specific gravity (after charging) and general condition.
- 4) Check hydraulic oil level, ISO Grade 22 (Europe), Grade 32 (Rest of World).
- 5) Inspect the engine air filter and clean or replace if necessary.
- 6) Check operation and security of stabiliser micro switches in conjunction with the alarm system.
- 7) Inspect hose track for damage or missing parts.



### **3.3.3 MONTHLY SAFETY CHECKS**

- 1) Check the engine oil level (if applicable).
- 2) Check the wheel nuts (torque 65ft lbs / 86Nm).
- 3) Check outriggers for condition, security and operation.
- 4) Check that the slew worm is secure and correctly in mesh. Clean and re-grease.
- 5) Inspect brakes for operation and wear.
- 6) Grease the knuckle and centre post.
- 7) Inspect the engine fuel tank for damage or leaks.
- 8) Check telescopic boom wear pads and nylon studs (if applicable).
- 9) Lightly oil the outrigger pad ball joints and outrigger housings.
- 10) Check that the bolts holding the wheel motors to the chassis are secure.
- 11) Every **three** months check and verify the calibration of the cage weigh system. See section 4.5.4 for the calibration procedure.
- 12) Every **Six** months perform a **thorough examination** in accordance with the 'Lifting Operation and Lifting Equipment Regulations' (LOLER) 1998, Regulation (9)(3)(a).

### **3.3.4 ANNUAL SAFETY CHECKS**

- 1) Check that all pivot pins and their tag bolts are secure.
- 2) Inspect for any cracks or badly rusted areas on booms and chassis.
- 3) Change the hydraulic oil filters.
- 4) Inspect the suspension on each rear axle unit.
- 5) Check that slew ringbolts are secure (torque 155ft lbs. 210Nm).

**Operating & Safety Instructions****3.4 PLACARD, DECALS & INSTALLATION (UK)**

ITEM	DESCRIPTION	NUMBER	QTY	
1	Tilt alarm	P18842	2	
2	General Crush	P14782	8	
4	Harness Point	P14883	2	
5	Component Stability	P19708	1	
6	No Step	P14785	6	
7	Manual Hand Pump	P19090	1	
9	General Warning	P20330	2	
10	Head Protection	P14921	1	
11	Serial Plate	P15383	1	
13	SWL 200kg	P14801	1	
14	Nifty SD170 - Grey	P14600	2	
15	Niftylift.com	P14390	1	
16	Cage levelling	P10853	1	
17	Hydraulic Controls – 3 lever	P14926	1	
18	Hydraulic Controls – 5 lever	P14927	1	
19	Warning Stripes		A/R	
20	If E-Stop disabled...	P14864	2	
21	Drive/Steer	P15637	1	
22	Base Control	<i>Cage weigh</i> <i>Non cage weigh</i>	P17219 P15881	1 1
23	Trip Switch Reset	P19056	1	
24	Outriggers - Hydraulic	P14841	4	
25	Drive Wheel Lock	P19444	1	
27	Footswitch	P14884	1	
28	Function Selector (2WD Only)	P15636	1	
29	Brake Override	P19986	1	
30	Battery Disconnect	P19700	1	
32	Battery Charger	P14904	1	
33	Outrigger Control (2WD Only)	P15635	1	
34	Point Load - 15.7 kN (2WD)	P14966	4	
36	Cage Control	P18961	1	
39	Diesel ONLY	P14414	1	
40	Point Load - 17.5 kN (4WD)	P14967	4	
41	Outrigger Control (4WD Only)	P11903	1	
42	Operating Instructions	P14892	1	
43	Cage rotation	P15634	1	
44	Overload Warning	P18848	2	
45	Noise Warning	P17124	1	

**nifty**  
**170SD Series**

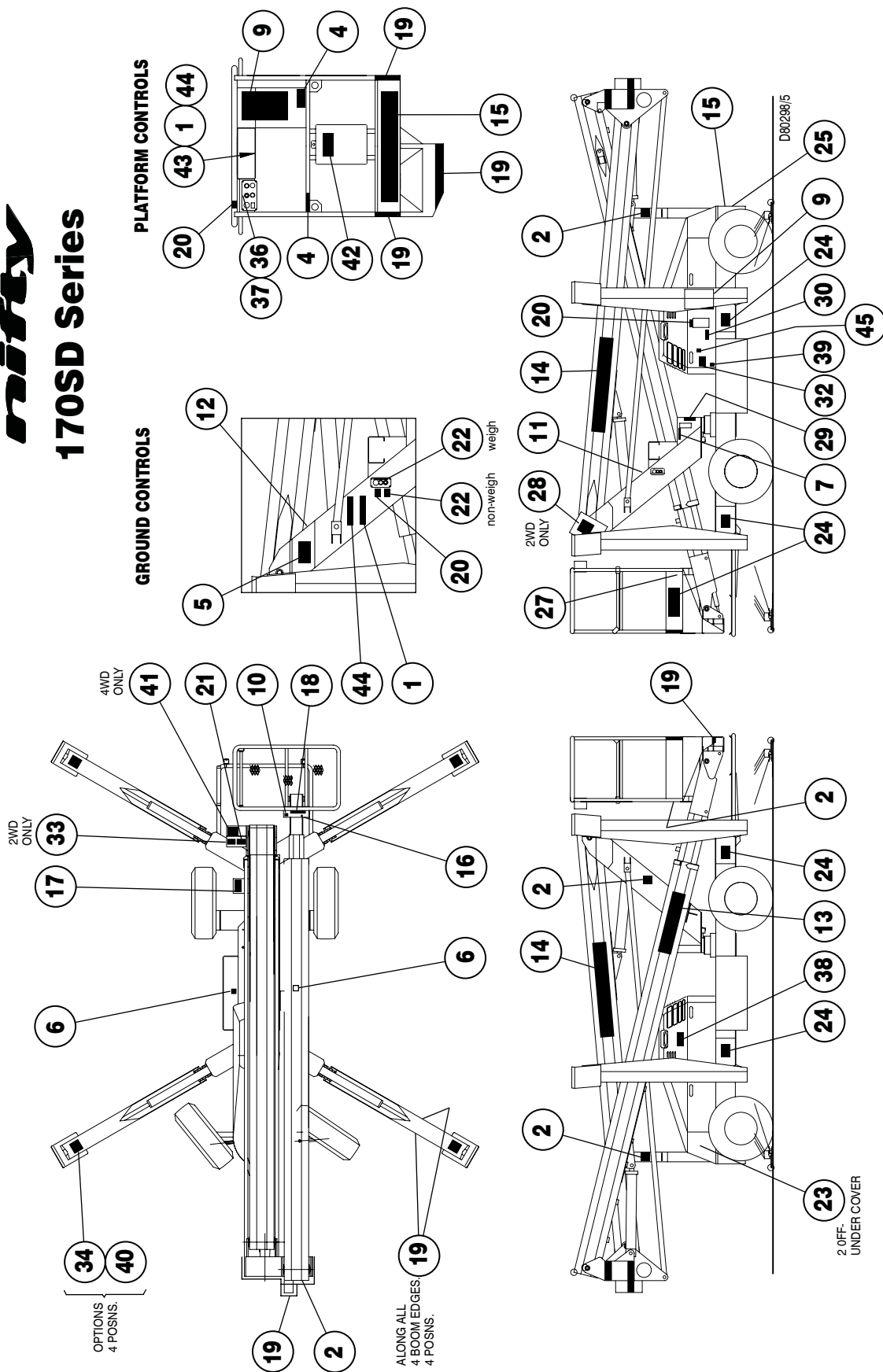

**3.4 PLACARD, DECALS & INSTALLATION (USA)**

<b>ITEM</b>	<b>DESCRIPTION</b>	<b>NUMBER</b>	<b>QTY</b>
1	Emergency Stop	P14864	3
2	Outrigger Alarm	P18842	2
3	Crush Hazard - Verbal	P14783	4
4	Crush Hazard - Pictorial	P14782	6
6	Battery Acid	P14872	2
7	Rotating Machinery	P15010	2
8	Operating Instructions	P14892	1
9	Manual H/pump	P19090	1
10	Trip - Reset	P19056	3
11	Outriggers	P14836	4
12	Boom Clamp	P14841	2
13	Battery Isolator	P19700	1
14	Wheel Release	P19444	1
15	Pinch Point	P14782	5
16	Footswitch	P14884	1
17	Harness Points	P14883	2
18	Component Stability	P19708	1
19	Outrigger Controls	(2WD) P15635	1
		(4WD) P11903	1
20	Cage Rotation	P15634	1
22	General Warning	P20330	1
23	Battery Charging	P14904	1
24	No Step	P14785	8
25	Head Protection	P14921	1
26	No Step	P14785	6
27	Drive/Steer	P15637	1
29	Daily Safety Check List	P14908	2
30	General notice	P18863	1
32	Charger Supply	P14904	1
33	Ground Levers	P14926	1
34	Platform Levers	P14927	1
35	Pushbuttons	P18961	1
36	Platform Capacity (500 lbs)	P17328	1
37	Base Key Switch	P15221	1

**nifty** SD Series  
**Operating & Safety Instructions**

ITEM	DESCRIPTION	NUMBER	QTY
38	Diesel Fuel Only	P14414	1
39	Identity Plate	P15383	1
40	'Niftylift.com	P14390	1
41	Nifty SD50	P14618	2

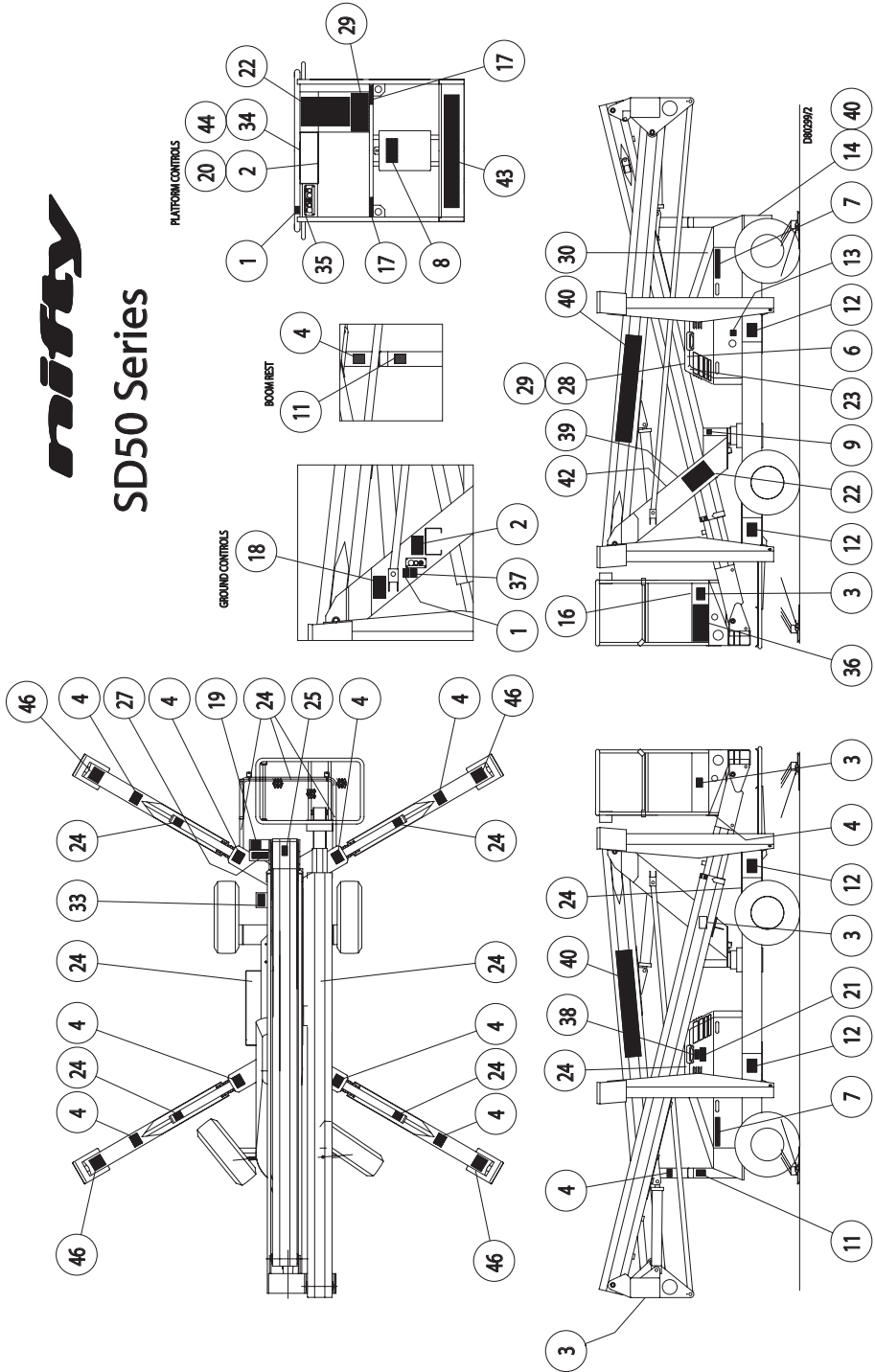

**nifty**  
**SD50 Series**

**3.5 TORQUE REQUIREMENTS**

SCREW QUALITY/SIZE	Tightening torque in ft lbs (Nm)			
	Grade	8.8		10.9
M 6	7.4	(10)	10	(14)
M 8	18.5	(25)	26	(35)
M 10	36	(49)	51	(69)
M 12	65	(86)	89	(120)
M 14	100	(135)	140	(190)
M 16	155	(210)	218	(295)
M 18	215	(290)	300	(405)
WHEEL NUTS	65ft lbs		86Nm	
WHEEL MOTOR NUTS	340ft lbs		460Nm	
SLEW RING BOLTS	155ft lbs		210Nm	

## **4 Operation**

### **4.1 CONTROL CIRCUIT COMPONENTS**

**4.1.1 CONTROL BOARD:** - Situated under the canopy, the encapsulated control board comprises of a PCB (printed circuit board) design which incorporates all of the relays to control the machine operation. The control board is common to all models and contains functions which might not be utilised on your machine. A thermal trip switch is integral to the box, which protects the control circuit components. If power is lost, the switch can be manually reset.

**4.1.2 TILT ALARM:** - Fitted to the top of the control board box, the tilt alarm is a solid state sensor which monitors the inclination of the machine. It directly controls the BRV (Brake Release Valve) and if the machine had been set up on an excessive incline would sound the alarm. Platform operation is unaffected, allowing the operator to stow the machine. This then restores the drive and it is then possible to drive back onto level ground, fully restoring machine operation. The tilt alarm does not operate when the machine is being driven, as the boom switch overrides this function as long as the booms are lowered.

**4.1.3 SOUNDER:** - Situated beneath the PCB is a small electric sounder, which is used to provide an intermittent alarm whenever the machine is in operation. Pushing a green “power control” button or depressing the foot switch in the cage (if fitted) will energise this sounder. This serves to warn personnel of the operation of the machine.

**4.1.4 KLAXON:** - Also mounted on the top of the control board box is a klaxon, which performs several functions.-

Firstly, it can be used as a manual alert, by pushing the “Horn” button at the Platform Control Station.

Secondly, it is the device which sounds continuously if the tilt alarm sensor detects excessive inclination, with the booms raised.

Lastly, it is linked into the battery management system, such that when low battery state is reached the “pulsing” of the DC motors is mimicked by the Klaxon, re-enforcing the message to the operator to re-charge the batteries.

**4.1.5 DRIVE CONTROL VALVE (DCV):-** The motion control valve comprises of several individual components all directly involved in the hydraulic supply to the wheel drive motors. Principal amongst these are the drive control valves, which electrically change the drive motor hydraulic supply from series flow to parallel, or vice versa. This control function is only available when the booms are lowered and allows the operator to select “Hi” or “Lo” drive. “Hi” drive gives fast speed of travel, but low gradeability, “Lo” drive gives best gradeability, but slow speed. “Lo” drive is used for climbing inclines and delicate positioning of the machine.

**4.1.6 BRAKE RELEASE VALVE (BRV):-** The motion control valve also incorporates a solenoid operated dump valve which controls the brake function on the machine. This valve must be energised to allow the machine to move. If no voltage is present, the wheel motors will not be able to develop drive torque, whilst at the same time, the spring applied parking brakes will remain engaged. Only when the green “power control” button is being used (or the platform foot switch is depressed) will the BRV operate. If the tilt alarm sensor detects an excessive inclination whilst the booms are raised, it is the BRV which is de-energised to isolate the machine (at the same time the Klaxon tone changes to a continuous one to indicate this condition).

- 4.1.7 BOOM SWITCH:** - Mounted on the boom rest on Boom 1, and operated by the upper boom, this switch controls both the operation of the tilt alarm sensor, and the outrigger interlock. With the booms in the stowed position, the tilt alarm sensor is bypassed, allowing the machine to negotiate slopes in excess of the permissible working angle, without isolating the drive function. At the same time, "Hi" drive is possible, as is fast throttle on those machines so equipped. When the booms are raised, the tilt alarm sensor becomes activated, and the boom switch isolates the outrigger control circuit. These control functions are of primary importance to the safety of the machine and operator; under no circumstances should this control function be isolated or bypassed.
- 4.1.8 BATTERY MANAGEMENT:** - Battery condition is permanently monitored by the control circuit, such that when available power has decreased to 20% of full charge, the battery status circuit begins to "chop" the power to the hydraulic power packs. This function causes the drive system to alternately stop and start, signalling to the operator that re-charging is necessary. At the same time the Klaxon will begin to sound intermittently re-enforcing the charge warning. At this point, sufficient power remains to drive to the nearest power point. Should the operator ignore the on-set of the discharge warning, the "chopping" will continue until the machine is rendered inoperative. Immediate charging will then be required.
- Under no circumstances should a machine be left fully discharged or severe battery damage can occur in a relatively short time.
- 4.1.9 BATTERY ISOLATOR:** - A battery disconnect switch is located beneath the centre bonnet section which allows the machine control and power circuits to be isolated from the batteries themselves. Under normal operation, the machine key switch should be used to isolate the machine, with the Battery Isolator only being required for emergencies to disconnect the batteries in the event of a short circuit. The battery charging circuit is connected directly to the battery side, so charging is unaffected by use of this switch.
- 4.1.10 DUTY SELECTOR:** - On multiple power option machines, one of the functions on the Platform Control Station will be a Duty Selector. This key switch allows the selection of either power option i.e. from Diesel to Battery, or Petrol to Battery, or vice versa. On other machines this same key switch serves as an "ON-OFF" control.
- 4.1.11 DIESEL ENGINE:**-Generally a Kubota D722-E engine (OC95 on 2WD), described in the maintenance section of the Workshop Manual, driving a twin bodied pump with direct mounted pump dump valves (one per section). The arrangement allows two speed operation and fast throttle.
- 4.1.12 DIESEL BOX:** -Located adjacent to the Diesel engine, the Diesel box combines all of the functions for Dual power operation, (Bi-Energy machines), as well as controlling the Diesel engine itself. The relays in this box control Starting, High Throttle, Pump Dump, Duty Selector and Diesel Stop Timer. There is also an integral Thermal trip, which protects the Throttle solenoid and other functions.
- 4.1.13 PETROL (GASOLINE) ENGINE:**-Generally a Honda engine, described in the maintenance section of the Workshop Manual, driving a single body pump with direct mounted pump dump valve. The engine is also equipped with a throttle solenoid for two speed operation.



- 4.1.14 PETROL (GASOLINE) BOX:-** Located adjacent to the petrol (gasoline) engine, the Petrol (gasoline) Box combines all of the functions for dual power operation, as well as controlling the petrol engine itself. The relays in this box control Starting, High Throttle, Pump Dump, Duty Selector and Engine Stop. There is also an integral Thermal trip, which protects the Throttle solenoid and other functions.
- 4.1.15 LPG OPERATION:-** On machines equipped for LPG operation (propane) the Honda engine will also have an LPG vaporiser, valve lock and micro-vac switch. The supply and regulation of the propane is governed by the installed gas bottle and regulator. The vapour take-off system requires a vaporiser to convert the liquid gas into an airborne mixture. This is then held by the micro-vac switch and valve lock until the engine turns over, creating a vacuum on the inlet to the engine carburettor. The micro-vac switch then tells the valve lock to open, admitting the gas to the engine. If the engine is halted, the system returns to normal, holding the gas until a re-start is attempted. When running on Petrol, the main tap to the gas bottle should be securely closed, to prevent the engine from trying to run on a mixture of the two fuels. If starting to run on LPG, it should be ensured that all petrol is discharged from the carburettor bowl before changing to LPG, since the engine will not run satisfactorily if any petrol is in the carburettor bowl.
- 4.1.16 FUNCTION SELECTOR: Two Wheel Drive:** Situated adjacent to the drive/outrigger controls is a two position hydraulic hand valve which allows the machine's hydraulics to be directed to either the outrigger/drive circuit (downwards) or the boom operation (upwards). The outrigger/drive circuit requires the booms to be lowered in order to operate. The boom circuit needs all four outriggers to be in contact with the ground before it will operate.
- Four Wheel Drive:** The hand operated duty selector is situated adjacent to the drive/steer joystick and the electrical solenoid outrigger controls. Grasping the handle automatically routes the hydraulic flow through to the outrigger and drive circuit and at the same time operates the micro switch to run the appropriate power option chosen. This then permits the use of either outrigger deployment or machine drive. Releasing the spring loaded handle returns it to the boom position. As soon as the boom raises, the electric micro switch is disabled denying the use of the outrigger and drive functions whilst elevated. As before, the boom circuit needs all four outriggers to be in contact with the ground before it will operate.
- 4.1.17 SPEED CONTROL:** A two position selector allows high throttle for the engine to be selected, or twin power pack operation for fast speed duty. This will operate when the booms are lowered, to allow fast set-up of the outriggers, and fast drive speed.
- 4.1.18 2WD:** Machine is two wheel drive and front wheel steer. Braking is hydrostatic on the front wheels and with mechanical parking brakes on the rear wheels. Speed control is fully proportional with hi/lo throttle control and series/parallel switching of the drive motors. (Tortoise/hare).
- 4.1.19 4WD:** This variation is four wheel drive and front wheel steer. Braking is hydrostatic on all wheels and with fail-safe hydraulic parking brakes on the rear wheels. Speed control is fully proportional with hi/lo throttle control and series/parallel or parallel/parallel switching of the drive motors (Tortoise/Hare).

## 4.2 SETTING UP PROCEDURES

**FAILURE TO DEPLOY THE OUTRIGGERS CORRECTLY COULD RESULT IN DEATH OR SERIOUS INJURY.**



### ALL MODELS

- 1) Read and fully comply with all safety precautions and operating instructions in the Operating and Safety manual and the warning decals on the machine.
- 2) Position Niftylift on firm ground, bearing in mind range of boom movement so that any overhead obstructions or possible hazards such as, but not limited to, power cables, telephone lines, drains, manhole covers, etc. can be safely avoided
- 3) If the load bearing capacity of the ground is in any doubt the machine must **NOT** be used.
- 4) Levelling the machine using the hydraulic outriggers can accommodate a slope of up to 12 degrees, if necessary using suitable load bearing pads to support the downhill jacks. Do not elevate the platform unless the base can be corrected to within three degrees of level.
- 5) Chock wheels and cordon off area using appropriate cones, barriers and flags.
- 6) Release boom travelling clamp. (If applicable)
- 7) Check all red emergency stops are not engaged i.e. fully out.
- 8) Ensure selector valve adjacent to drive/outrigger control station is turned fully down to outrigger/drive position. (For four wheel drive machine grasp and hold duty selector. Power will be available automatically).
- 9) From the cage control station depress and hold the green power button or footswitch to give hydraulic power to the outriggers and select the appropriate control lever. Note: No power will be available if the booms are not stowed onto the boom rest.
- 10) Using the four outrigger control levers, (toggle switches on 4WD), lower each outrigger onto a firm, level surface and level machine base ensuring each outrigger foot is taking equal weight with the wheels clear off the ground.
- 11) Check machine is level using spirit level on the base, visible from the cage.
- 12) Change selector valve at drive/outrigger control station to platform, i.e. turn fully up. (On four wheel drive machines, releasing the duty selector handle automatically returns the machine to "platform" operation).
- 13) The booms can now be operated from the ground or cage control station by depressing and holding the green power button. Note: If no power is available check each outrigger is lowered and each footpad is taking equal weight.
- 14) Always lower booms fully before adjusting, raising, retracting or moving the outriggers in any way.
- 15) Never alter, modify or block any of the safety circuits on the Niftylift.

## **4.3 GROUND CONTROL OPERATION**

**ALWAYS ALLOW THE ENGINE TO WARM UP BEFORE OPERATING.**



### **4.3.1 GROUND CONTROL INSTRUCTIONS**

#### **ALL MODELS**

- 1) Ensure all red emergency stops are out.
- 2) Turn key switch at ground control station to ground (i.e. fully down).
- 3) Ensure selector hand valve (if applicable) is turned to platform position (i.e. fully up).
- 4) Battery electric models go to step 11.

#### **DIESEL ENGINE OR BI-ENERGY MODELS**

- 5) For a cold engine start, go to step 6) or for a warm engine go to step 7).
- 6) **COLD ENGINE:** - turn the main engine ignition switch (located beneath the front cover) through "ON" to "GL". This engages the glow plug pre-heat system. Hold for 3-5 seconds then turn key fully to "ST" (start) position and the engine will fire.
- 7) **WARM ENGINE:** - turn the main engine ignition switch (located beneath the front cover) through "ON" to "ST" (start) position and the engine will fire.

*Note – Unless the diesel engine is running, the SD170 will automatically default to the primary power source (usually battery).*

#### **PETROL (GASOLINE) ENGINE OR PETROL (GASOLINE)/ELECTRIC MODELS**

- 8) For a cold engine start, go to step 9) or for a warm engine go to step 10).
- 9) **COLD ENGINE:** - turn the engine fuel tap on and engage the choke lever. Turn the main engine ignition through "ON" to "ST" (Start) and the engine will fire. Return the choke lever to its normal running position after the engine is started.
- 10) **WARM ENGINE:** - turn the engine fuel tap on and turn the main engine ignition through "ON" to "ST" (start) position and the engine will fire.

*Note – Unless the diesel engine is running, the SD170 will automatically default to the primary power source (usually battery).*

#### **ALL MODELS**

- 11) Push and hold green power button.
- 12) Select function and operate hand levers in full accordance with manufacturers Operating and Safety manual. Note: all outriggers must be down before booms can be operated.
- 13) To return control to platform turn key fully clockwise to up position.
- 14) When not in use return machine to stowed position, fully raise and stow all outriggers, turn the key to the centre off position, remove key and chock wheels.

**EMERGENCY PROCEDURES**

- 1) Push in red emergency stop to shut down all functions.
- 2) Use manual hand pump to manoeuvre machine into a safe place. Base or cage controls can be used whilst the hand pump is being operated. Only when the machine is fully stowed should the flow be directed to the outrigger controls in order to recover the outriggers. Failure to follow this procedure could result in serious injury or risk of death.

**4.3.2 BOOM FUNCTIONS**

- A) Push and hold green power button.

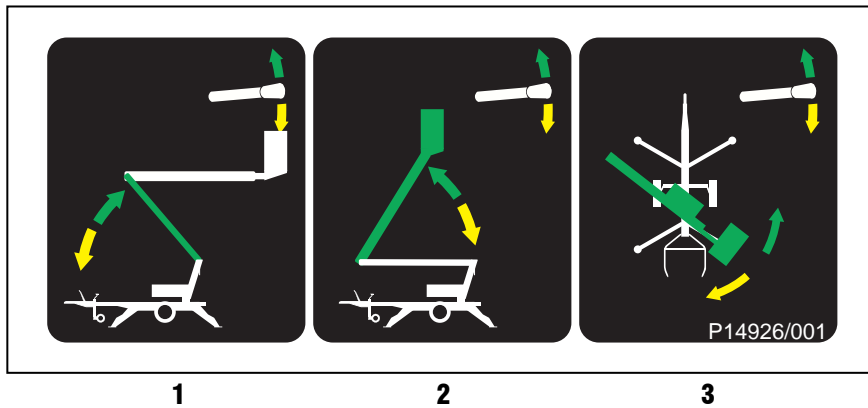

- B) Select lever 1, 2, or 3 for desired boom function.

<b>1</b> Operates Lower Boom	<b>UP</b> for up	<b>DOWN</b> for down
<b>2</b> Operates Upper Boom	<b>UP</b> for up	<b>DOWN</b> for down
<b>3</b> Operates Swing	<b>UP</b> for right	<b>DOWN</b> for left



**ALWAYS ENSURE THE AERIAL PLATFORM IS ON A FIRM SURFACE AND THE AREA IS FREE OF ANY OVERHEAD OBSTRUCTIONS.**

**ENGAGING THE RED EMERGENCY STOP BUTTON WILL SHUT DOWN THE ENGINE, AND THE ELECTRIC CIRCUIT PREVENTING OPERATION OF ANY FUNCTION.**

## 4.4 PLATFORM CONTROL OPERATION



**NEVER START THE NIFTYLIFT IF YOU SMELL GASOLINE (PETROL), LIQUID PROPANE OR DIESEL. THESE FUELS ARE FLAMMABLE.**

**BEFORE OPERATING THE NIFTYLIFT ENSURE THAT EACH OPERATOR HAS READ AND FULLY UNDERSTOOD THE OPERATING MANUAL. FAILURE TO DO SO MAY RESULT IN DEATH OR SERIOUS INJURY.**

### 4.4.1 PLATFORM CONTROL INSTRUCTIONS

#### **ALL MODELS**

- 1) Ensure all red emergency stops are out.
- 2) Turn key switch at ground control station fully up to platform position.
- 3) Ensure selector hand valve (if applicable) is turned to platform position, i.e. fully up
- 4) Battery electric models go to step 11).

#### **DIESEL ENGINE OR BI ENERGY MODELS ONLY**

- 5) For a cold engine start go to step 6) or for a warm engine start go to step 7).
- 6) **COLD ENGINE:** - turn the engine ignition switch (on the platform control box) to the Glow position (anti-clockwise). This engages the glow plug pre-heat system. Hold for 3-5 seconds then turn the switch to the Start position (fully clockwise) and the engine will fire.
- 7) **WARM ENGINE:** - - turn the main engine ignition switch (on the platform control box) to the Start position (clockwise) and the engine will fire.

#### **PETROL ENGINE OR PETROL/ELECTRIC MODELS ONLY**

- 8) For a cold engine start go to step 9) or for a warm engine start go to step 10).
- 9) **COLD ENGINE:** - (From the ground only) turn the engine fuel tap on and engage the choke lever. Turn the main engine ignition through ON to ST (Start) and the engine will fire. Return the choke lever to its normal running position after the engine is started.
- 10) **WARM ENGINE:** - Ensure the main engine ignition switch is ON. Turn the 3 position engine ignition switch to the right and the engine will fire. When released, the selector will return to the centre, 'OFF' position.

#### **ALL MODELS**

- 11) Depress foot switch or push and hold green power button.
- 12) Select function and operate hand levers in full accordance with manufacturers Operating and Safety manual.
- 13) When not in use return booms to stowed position. Fully raise and stow all outriggers. Turn key switch at ground control to centre off position, remove key and chock wheels.

**4.4.2 PLATFORM PUSH-BUTTON CONTROLS STATION**

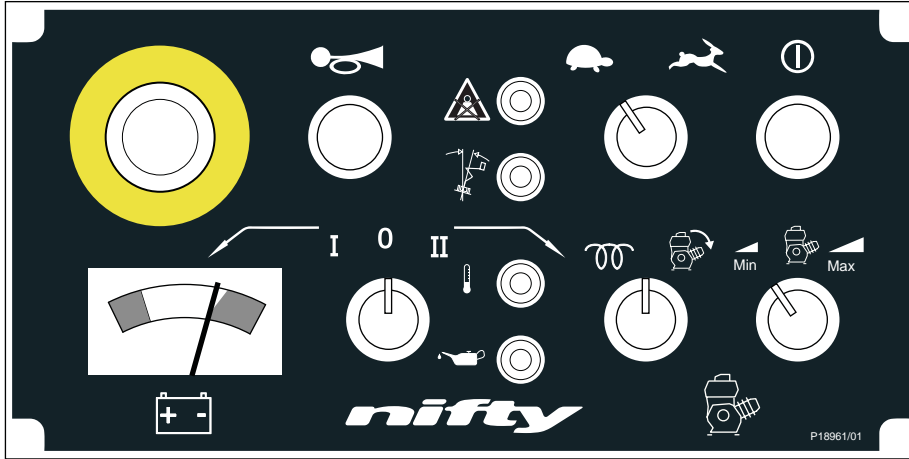

**(BI-ENERGY MODEL SHOWN)**

**4.4.3 DRIVE AND OUTRIGGER FUNCTIONS**

Situated at the top of Boom 1 (superstructure) is the 5 lever drive/outrigger hand valve. These control the following functions:

**Left hand lever:** Two axis joystick for drive; Up for Forward, Down for reverse & Steer: Left for Left, Right for Right

**The remaining 4 levers:** Control the outrigger deployment as indicated on the label below. (Mounted adjacent to the outrigger control position). **Two wheel drive machine only.**

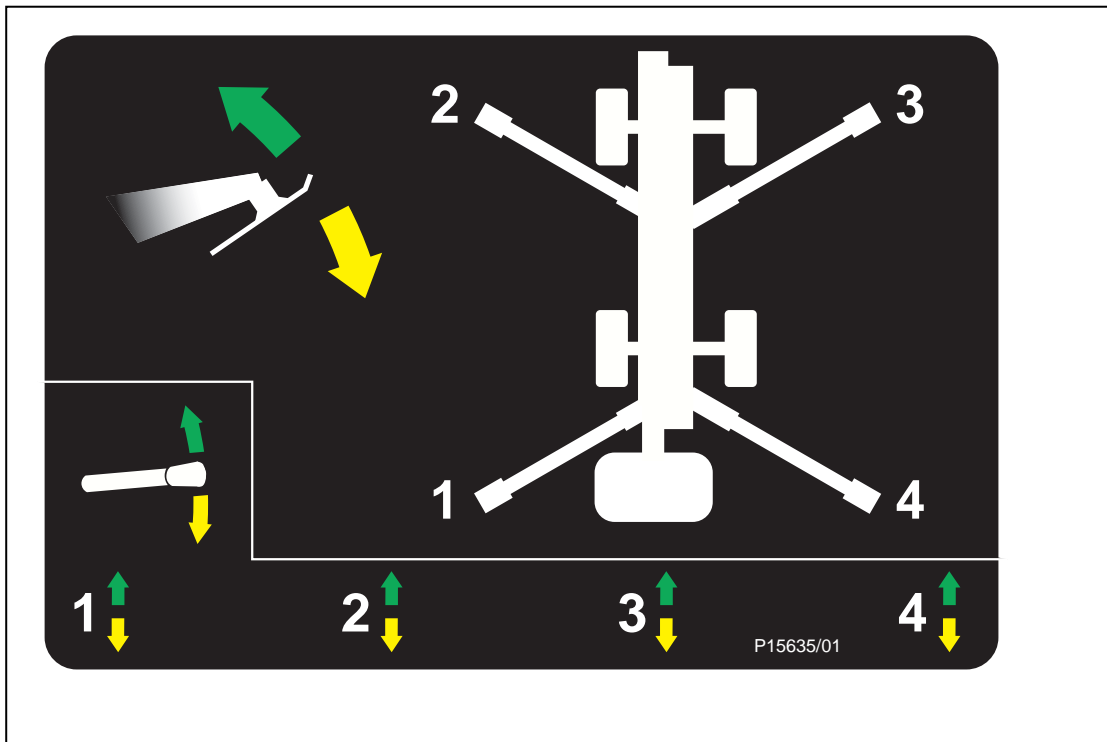

**FOUR WHEEL DRIVE: OUTRIGGER CONTROL**

Situated adjacent to the single drive/steer joystick is the box comprising of the toggle switches controlling each stabiliser leg. These operate individually to either lower or raise each leg, and provide the levelling function for the machine base.

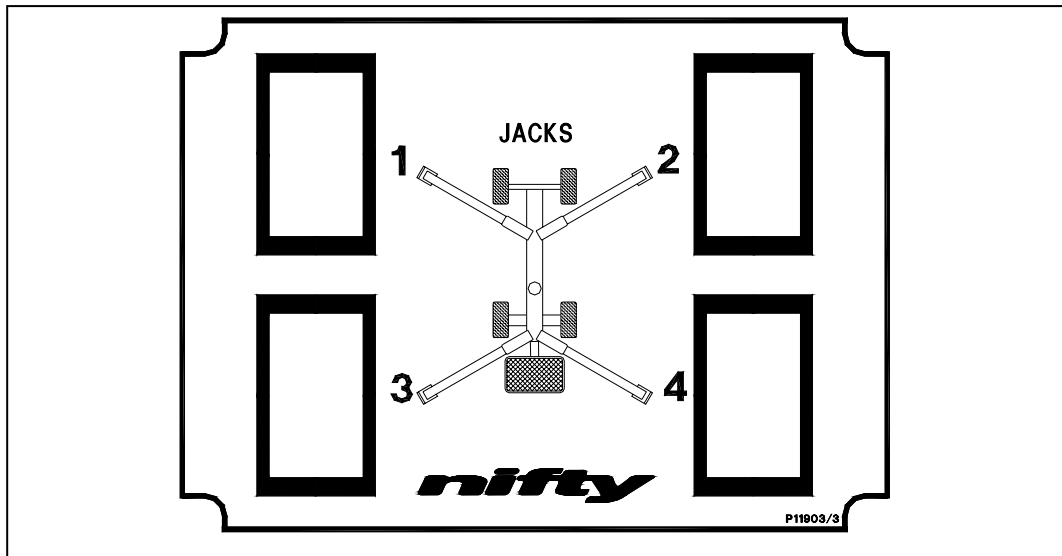

**Operating & Safety Instructions**

**4.4.4 BOOM CONTROLS**

- 1) Never exceed the maximum platform capacity of 200kg (440lb) (500lb in USA).
- 2) Check below, above and around the platform for any obstruction or hazards before operating any function.
- 3) Depress foot switch or push and hold green power button.

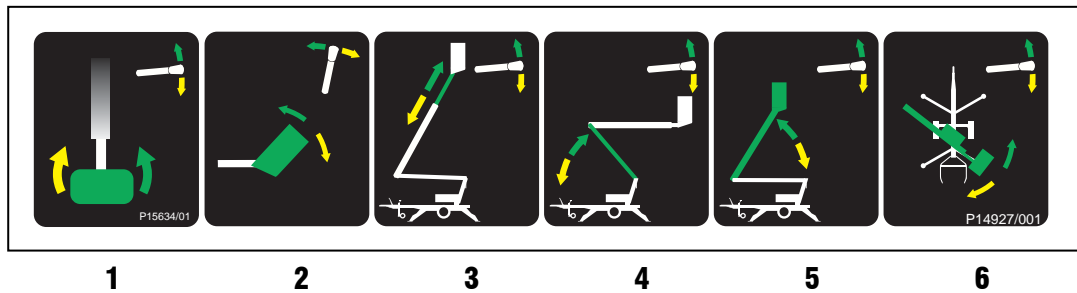

- 4) Select lever **1, 2, 3, 4, 5** or **6** for desired boom function.

<b>1</b> Operates Cage Swivel (optional)	<b>UP</b> for right	<b>DOWN</b> for left
<b>2</b> Operates Cage Levelling	<b>FORWARD</b> for forward	<b>BACK</b> for back
<b>3</b> Operates Telescope	<b>UP</b> for telescope out	<b>DOWN</b> for telescope in
<b>4</b> Operates Lower Boom	<b>UP</b> for up	<b>DOWN</b> for down
<b>5</b> Operates Upper Boom	<b>UP</b> for up	<b>DOWN</b> for down
<b>6</b> Operates Swing	<b>UP</b> for right	<b>DOWN</b> for left



**IF ALARM SOUNDS - DESCEND IMMEDIATELY**

**THIS MACHINE IS NOT ELECTRICALLY INSULATED. DO NOT WORK WITHIN 10FT (3M) OF OVERHEAD CABLES EXCEEDING 415 VOLTS**



## **4.5 CAGE WEIGH SYSTEM**

### **4.5.1 MECHANICAL VERSION**

The Niftylift range of machines are available fitted with mechanical cage weigh systems. These are configured to sense a vertical cage overload, which when detected will halt the machine movement. No further use of the platform is then permitted until the overload has been removed. This must be done in a responsible manner and not one in which a greater hazard might be induced. Therefore, if the addition of external items such as light fittings; brickwork or tiles etc were allowed into the cage, the machine would not operate. In order to restore the functions, the excess load should be safely removed, NOT by discharging them out of the basket to the detriment of persons below.

The mechanical cage weigh system works on the principle of a pre-loaded spring, rated to the cage safe working load. Excess load in the cage forces the spring to further compress, the movement of which is detected by a precision micro-switch. With the machine turned 'On', this movement first gives an audible alarm in the cage, as well as a visual indication at both control positions (cage and base). Additional deflection due to increased load serves to cut off the machine control circuit, effectively halting all machine movements.

Under the circumstances where the cage overload cannot be removed, the machine can only be manoeuvred by use of the manual hand pump. Great care must be taken when utilising this facility, especially if the machine is significantly overloaded; any motion that causes the machine outreach to increase could induce instability. The machine must be manoeuvred in such a manner as to reduce outreach, then height, until a safe level is reached to permit the operator to dis-mount or the overload to be removed.

### **4.5.2 FUNCTION**

The cage overload system is powered from the machine control circuit, so the system is inactive if the machine is turned 'Off'.

'Enabling' the emergency stops allows the system to become 'active', when either the cage or base key switch is turned 'On'. If the cage is overloaded, the control circuit will immediately indicate this by the audible and visual alarm. Pressing the emergency stop or turning the key switch to the 'Off' position merely silences the alarm. The alarm will continue to sound as long as the overload persists, unless the machine is turned 'Off'.

Whilst the overload is detected, pressing the green button at base or cage will generate no response from the control circuit. The machine will not function under power until the overload is removed. Removing the overload as previously described will re-set the system automatically, requiring no additional intervention from the operator. All machine functions will be restored.

### **4.5.3 TESTING**

At the simplest level, before working on the platform, the function of the cage overload can be checked by the following method: - Place two men into the cage and a larger quantity of tools than is permitted to be carried. (Typically 40 kg). The alarm should sound and all functions should be lost. Reducing the cage contents to the safe working load should silence the alarm and restore the machine operation.

### **4.5.4 CALIBRATION**

If a closer examination of the system is required, typically for testing and approval, the safe working load should be placed in the cage, carefully weighing the test load to ensure accuracy. The addition of a 5kg weight, to any of the four corners of the cage, should sound the alarm. If the alarm does not sound, carefully inspect the weigh mechanism for signs of damage. All parts of the weigh mechanism should be free to move, and the inspection should look for any impact damage that might have caused the assembly to become disabled, for any reason. If the mechanism seems to be functioning correctly, the adjustment of the weigh sensing micro-switch should be checked. A competent person, who has the authority to perform such adjustments, must perform this. Adjustment must not be permitted by anyone without the approval of the person responsible for the platform.

With the machine emergency stops 'enabled' and either the cage or base key switches turned 'On', the cage weigh micro switch is adjusted to bring the bolt into contact with the micro-switch roller. Continue adjustment until the alarm sounds, then back off slightly to silence the alarm. The locknuts supporting the adjustment bolt can be partially tightened to lock the bolt in place.

The addition of a 5 kg weight should now be used to prove that the system detects the applied overload, sounds the alarm and disables the machine. The sensitivity of the assembly is such that the alarm will sound slightly before the functions are disabled. The mechanism should be adjusted to allow the alarm to sound and functions to be lost within this 5 kg limit. Lock the adjustment screw securely.

The over-travel adjusters can now be used to protect the micro-switch from excess forces should a substantial overload be applied to the cage. (Typically if the machine is manoeuvred into contact with a fixed object, snagging the cage assembly, this would be detected as an overload to the system.) Adjust the screws forward until they come into contact with the cage weigh mechanism, then with the cage overload still applied and the alarm sounding, functions disabled and machine not operating, lock them in this position. Care should be taken to not turn the adjuster screws in too far; otherwise the overload signal might be lost.

The machine can then have the overload removed and the functions of the machine checked for correct operation.

### **4.5.5 INSPECTION**

The cage weigh system is controlled through the detection printed circuit board, part number P16164. This PCB is connected directly to the safety micro-switch and monitors the function of the cage weigh system. The two relays are configured such that both need to operate to permit safe operation of the assembly. Should either of them fail, an error signal is generated which can be seen on the printed circuit board itself. This occurs if pressing the green button does not allow the machine to operate, no overload signal to be given, with no load in the cage. In this case, open the cage pushbutton box or separate box containing the PCB and look at the printed circuit board.

There are three LED's (Light Emitting Diodes) on the board, Red LD1 for 'Overload', Red LD2 for 'Relay 1/2 failed' and Green LD3 for 'Machine enable'. The first indicates the overload when the machine is turned 'On', the second indicates a relay failure when the green button is pressed, and the third shows the machine is enabled, again when the green button is pressed.

The failure signal is generated if either relay fails to respond to the 'safe' cage weigh signal from the safety micro-switch, either due to a coil or contacts failing or if a contact sticks in place due to welding. Under either circumstance the 'enable' signal is blocked, instead generating the error message, illuminating the red LD2. The machine will not operate under this situation. The red error signal from LD2 requires the board to be changed, as the relays are not serviceable items.

#### **4.5.6 MAINTENANCE**

The cage weigh mechanism is supported on maintenance-free precision needle roller bearings for smooth running and friction-free operation. The accuracy of the entire assembly and in particular the hysteresis is dependent on these components. Keeping them free of dust and dirt is recommended; and an occasional application of WD40 to the external faces should keep them mobile and deny the entry of dust and moisture.

The hysteresis is the amount of load required to be removed before the system re-sets allowing continued operation.

If the assembly is subjected to any external impact force, typically whilst manoeuvring the machine under power, or in the case of trailer units, whilst being reversed into position, the cage assembly will require close inspection. If there is evidence of any deformation in any part of the structure, then the advice of a Niftylift Service technician should be sought. Physical damage to the assembly is liable to render the cage weigh system inactive, or to affect the accuracy of the result. Under no circumstance permit a damaged machine to enter service without performing a thorough inspection and calibration of the weigh assembly.

For this reason it is not recommended to restrain the machine in transit using strap or chains passed through or over the cage itself. This is particularly true of the electronic load cell system, which could be permanently damaged by the application of such excessive external forces. Whilst the mechanical system could be considered to be more robust in operation, the same restraint forces that could be generated through ratchet straps and the like, is likely to cause some severe deformation in the lightweight cage structure. Use only the designated tie-down points on your Niftylift when strapping the machine down for transport. Failure to observe this instruction could render the machine un-usable, and a considerable repair bill for the damaged components.

#### **4.5.7 REPLACEMENT**

If components are replaced, they must be genuine Niftylift parts. The accuracy and function of the cage weigh system relies on the like-for-like application of the component parts. A switch from a similar manufacturer might reverse the contact arrangement and critically affect the function of the mechanism. Similarly, the accuracy of the sensing circuit relies on the duplication of the contact travel within the switch itself. Using a non-equivalent component will render the cage weigh system inactive. Under no circumstances should you permit a machine with a defective cage weigh assembly to enter service.

If in doubt about the operation or function of your machine, always request the circuit diagram that goes with the machine serial number. Look at the bottom of the machine serial plate; one of the final two numbers stamped there will give the electrical circuit for the machine. ('D80000' number, plus the issue status immediately afterwards: - /01;/02;/03; etc, see Section 1.5 & 1.5a).

If in doubt, contact the Niftylift Service Department on (44) 01908 223456, Fax: 01908 227460.

## 4.6 DRIVING CONTROLS



**DO NOT OPERATE THE NIFTYLIFT WHILST ELEVATED UNLESS ON A FIRM, LEVEL SURFACE FREE FROM ANY POSSIBLE OBSTRUCTIONS OR HAZARDS BOTH AT GROUND LEVEL AND OVERHEAD.**

- 1) Check proposed route for possible hazards, obstructions and personnel.
- 2) Depress foot switch located in platform floor (if applicable). For 4WD machines grasp and hold the duty selector handle.
- 3) Use the **Drive Speed** selector on the platform control station to determine speed.

**High Drive** (Hare) - GIVES HIGH SPEED AND LOW GRADEABILITY.

**Low Drive** (Tortoise) - GIVES LOW SPEED AND HIGH GRADEABILITY.

- 4) Select drive joystick from hand lever controls (left hand lever of five, situated at the drive/outrigger control position).
  - A. Up for **FORWARD**
  - B. Down for **REVERSE**
  - C. Left for **STEER LEFT**
  - D. Right for **STEER RIGHT**
- 5) All control levers give a fully proportional response therefore the more the lever is moved away from the centre (OFF) position the faster the function will become.
- 6) Maximum drive speed is only attainable when all booms are fully stowed and the **HI/LO** selector is in the **HI** position.
- 7) When driving with the booms fully stowed, the Tilt Alarm is bypassed to allow the Niftylift to be driven in areas where the slope exceeds the five degree working limit. In normal operation the drive is therefore unaffected when driven onto a slope in excess of five degrees, until the outriggers are lowered and the booms are raised, whereupon the drive would be disabled and the tilt alarm sounds continuously.
- 8) Under no circumstances should any Niftylift SD series machine be driven on slopes exceeding 25%, with the booms fully stowed (30% for 4WD machine).

## 4.7 BATTERIES AND CHARGING



**BATTERIES MUST BE RECHARGED IN A WELL-VENTILATED AREA FREE OF FLAME, SPARKS OR OTHER HAZARDS THAT MAY CAUSE EXPLOSION. HIGHLY EXPLOSIVE HYDROGEN GAS IS PRODUCED DURING THE CHARGING PROCESS.**

- 1) Recharge batteries at the end of every working day or shift.  
(**Note:** To recharge batteries fully from flat takes approx. 12 Hours, this consists of 8 hours bulk charging plus 4 hours equalisation).
- 2) Plug charger into suitable power supply, either 240 volts or 110 volts AC (see **Charging Limitations**). (Note: If using 240V, use of a suitably rated Earth Leakage Circuit Breaker (ELCB) or Residual Current Device (RCD) at the point of supply is highly recommended.)
- 3) Take note of the indicators provided:  
**Red Light** - Batteries are charging.  
**Pulsing Green light** - the charge is equalising.  
**Constant Green light and pulsing Red light** - the batteries are fully charged.



**UNDER NO CIRCUMSTANCES SHOULD BATTERIES BE LEFT ON CHARGE FOR PERIODS IN EXCESS OF 24 HOURS**

- 4) **DISCONNECT FROM POWER SUPPLY ONCE BATTERIES ARE FULLY CHARGED.** The machine can now be left unattended, however, in the event of the machine being left unused for extensive periods then a **4 to 6 hour** 'top-up' charge every **4 weeks** is recommended. A 'top-up' charge the day before use ensures a full day of operation from the machine.



**UNDER NO CIRCUMSTANCES SHOULD A MACHINE BE LEFT FULLY DISCHARGED AS SEVERE BATTERY DAMAGE CAN OCCUR IN A RELATIVELY SHORT TIME.**

- 5) To avoid damage to charger disconnect from mains supply before using machine.

**Note:**

- 1) If the charger is reconnected to the power supply shortly after it has gone through its full charging cycle the Red LED may come on although the batteries may be fully charged. The charger would then go through its complete cycle again at an accelerated rate, depending on the time difference between connection, reconnection and level of battery charge.

### **Operating & Safety Instructions**

- 2) Some Niftylifts are fitted with a Battery Management System, which permanently monitors the condition of the batteries. When the batteries become discharged to 20% of their capacity the management system will begin to "shut down" the hydraulic power packs. This causes the drive/boom operating system to alternately stop and start, signalling to the operator that re-charging is necessary. However, there is sufficient power remaining to enable the operator to drive slowly to the nearest charging point.

Should the operator ignore the onset of the battery discharge warning the "shut down" of the motors will continue, until the machine is rendered in-operative. **Immediate charging will then be required.**

#### **CHARGING LIMITATIONS**

Battery charging times will increase slightly if using an 110V supply as opposed to a 240V supply. This is due to the connection of the primary coils being in parallel, which in effect only allows the transformer to see 220V. Similarly, the capacity of the 110V supply will decide the input current available; hence a small hand-tool transformer will not operate the battery charger efficiently, therefore: - charging times will increase further due to input limitations.

Attention should also be given to the use of extension cables as power leads. Excessive cable lengths from the supply point to the battery charger will result in significant voltage drop, leading to a reduction in the chargers efficiency. In addition, inadequate sized cable cores will have a limiting effect on its current carrying capacity, which will again lead to a reduction in the chargers efficiency. Both of these can result in over-heating of the cable with the attendant risk of fire, short circuits or damage to the components themselves.

The charger requires a minimum battery voltage of 4.5 volts per battery (overall for two batteries 9 volts, for 4 batteries 19 volts for 8 batteries 38 volts). If the voltage is below these values then the charger will not function (Charger will not detect batteries to begin charge.) If the batteries have fallen to such a poor state they will have to be removed from the machine and charged individually with an independent charger until the optimum voltage has been reached. This is best performed at very low currents to 'recover' the batteries if sulphation has already started i.e. a 'trickle' charger. This can take several hours, possibly days. Careful monitoring of the rise of battery voltage will indicate when recovery has been achieved.

#### **TOPPING UP**

During the course of normal operation, the batteries should be inspected at least once a fortnight to check the level of electrolyte. During the end of charge, gassing takes place, which will cause a slight reduction in the volume of acid in the battery. This can be topped up with de-ionised water as required. During this inspection, it is useful to note any imbalance in the fluid levels. One indication of a faulty cell would be an increase in the loss of battery acid, which would then require more frequent topping up on that cell, or cells. Faulty cells can liberate excess hydrogen, even during normal operation, with the resulting risk of explosion if ignited. **Any faulty batteries should be replaced as soon as possible with an equivalent sized and rated unit.**

**Note: BATTERIES CONTAIN ACID, therefore: - protective safety glasses and gloves (Appropriate PPE) MUST be worn whilst performing these checks.**

## **4.8 TRANSPORTING, TOWING, CRANEAGE, STORAGE AND SETTING TO WORK**

### **4.8.1 TRANSPORTING**

If a work platform is to be moved over a longer distance, whether the machine is trailer mounted, vehicle mounted, self propelled or tracked, the following procedure should be read before restraints are attached to the machine. Cross loading is most frequently the cause of problems, as the method of loading is no longer in sight of our own personnel. The recommendations made herein should be passed on to subsequent carriers, such that the entire journey is carried out without incident.

- Always ensure the truck or trailer you are loading or towing the Niftylift with can carry it legally.
- If loading by crane the use of shackles and an adequately rated spreader beam, with four leg slings, is **MANDATORY**.
- When loading or un-loading from the side of the vehicle, the use of the forklift pockets to retain one of the forks is recommended. (If fitted). Spread the forks to their widest capacity, with due regard to the components fitted to the machine. Never forklift or crane an entire machine under the booms, always lift beneath the spine or under the ends of the axle mountings in the case of a self-propelled unit. Ensure forklift is adequately rated for the load to be carried.
- Once positioned on the transport carrier ratchet straps should be used to secure the machine. The machine should be positioned to allow easy access around the machine in transit, and to ensure that 'creepage' during transport does not permit the machine to come into contact with other goods being shipped, or the container itself. Some movement of the machine structure might occur during transit, which could lead to fretting or other damage.
- If the machine is equipped with a transit device such as a boom clamp etc, this should be securely applied.
- Strap booms carefully to constrain them from sideways movement. When using straps or chains, adequate packing should be applied to stop any damage to the structure and paintwork. Due regard of the movement of the straps or chains must be taken into account.
- Where a machine has designated points for strapping, lifting or forking, these can be used for tie-down duty. When they are absent, the major structure of the platform can be used, giving due consideration to the design and function of the area chosen. Where possible, use the spine of the machine or axle mounts over which to apply the holding down forces. Using a single plate, such as an outrigger or stabiliser support plate might be unsuitable. If the component was clearly not designed to accommodate a side load, one should not be applied.
- Under no circumstances should straps or chains be applied over booms or through the cage support structure or the cage itself. The relative strength of the carrying structure is not conducive to the massive forces capable of being applied through ratchet chains or slings. Severe damage to the steelwork can be caused, as well as deformation to sensitive mechanisms such as cage weigh assemblies, which would render them useless. Such catastrophic damage to say, an electronic load cell would require the component to be replaced before the machine would function.

## **Operating & Safety Instructions**

---

### **4.8.2 TOWING**

Towing the Niftylift in case of an emergency.

#### **HYDRAULIC DRIVE MOTORS AND SPRING APPLIED BRAKES**

- 1) If parked on a slope securely chock all wheels.
- 2) Remove front cover: locate brake release valve and turn **anti-clockwise**. The rear wheel motors are now free of the hydraulic circuit.
- 3) Remove canopy: locate brake release lever and remove both springs. The rear wheel hub brakes are now released.
- 4) The Niftylift can now be towed over short distances - **maximum speed 5mph**.



**REMEMBER TO REPLACE SPRINGS AND RETURN HAND VALVE TO ORIGINAL POSITION BEFORE OPERATING THE NIFTYLIFT.**

**FAILURE TO DO SO WILL LEAVE THE MACHINE WITH NO HYDROSTATIC OR PARKING BRAKES AND NO DRIVE POWER.**

**Note! On later machines, un-braked steer hubs replace the front brake hubs and the drive motors have integrally braked gearboxes. In order to tow the machine the following procedure should be followed;**

#### **GEARBOX DRIVE MOTORS WITH INTEGRAL HYDROSTATIC BRAKES (NOT SPRING APPLIED)**

- 1) If parked on a slope securely chock all wheels.
- 2) Remove front cover: locate brake release valve (red, square knob) and turn **anti-clockwise**. The wheel motors are now free of the hydraulic circuit.
- 3) Move the brake override lever (adjacent to the ground controls - see page 42), to the **horizontal** position. Fit the manual hand pump handle and give the hand pump several pumps until pressure is felt to build. **2WD Only** - A visual check of the brake telltale (Located on the Drive Control Valve) will indicate when the brakes are released. When the indicator knob comes out of the block, the brakes are 'Off'.
- 4) The Niftylift can now be towed over short distances - **maximum speed 5mph**.
- 5) To re-set the brakes, move the brake override lever back to the normal 'up-right' position. Note; It may be necessary to cycle the lever more than once to re-set the brakes.  
**2WD Only** - The telltale indicator will return flush into the block.
- 6) In order to drive the machine once more, the brake release valve will need to be closed, by turning **clockwise**. The wheel motors are now re-connected to the hydraulic circuit.
- 7) If the brake override lever is not re-set manually, the next time the machine is moved hydraulically, the brakes will automatically re-set themselves. The brake override lever will however be in the wrong position for emergency operation of the booms, and should be returned to the normal 'up-right' position as soon as possible.



**4.8.3 CRANEAGE**

- 1) Observe all of the limitations relating to straps and chains stated above under 'Transporting'. (Section 4.8.1)
- 2) When utilising the designated lifting points never apply a 'snatch' load, i.e. lift slowly to take up the load before raising. Similarly, do not drop machine when positioning after lifting.
- 3) If the machine is to be lifted by crane, use the designated lifting points and observe the recommendations regarding spreader beams. Individual drawings are available for each machine type, on request. (See list below.)

**D80891**

D80461  
D80935  
D81301  
D80936  
D80937  
D80938

**SD170**

HR10/12  
HR15N  
HR17N  
HR15 4x4  
HR17 4x4  
HR21

**4.8.4 STORAGE**

If being stored for any length of time without use, then the machine should be thoroughly inspected for the following:-

- 1) Grease all bearings /slides, worm drives, etc.
- 2) Check batteries for electrolyte levels, state of charge, damage, dirt, etc. Never leave in a state of discharge for any length of time. If no use of the platform is intended, an occasional "top-up" charge of the batteries will serve to equalise their charge level.
- 3) Leave battery disconnect switch in OFF position to prevent discharge of batteries through leakage.
- 4) If machine is to be left on an incline, chock wheels to prevent creep.
- 5) If machine is to be left out-of-doors or in a hostile environment, cover with suitable weatherproof media to prevent deterioration.

**4.8.5 SETTING TO WORK**

Before use each day and at the beginning of each shift the machine shall be given a visual and functional test including, but not limited to, the following

- 1) Check all lubrication points for adequate application of grease, oil etc.
- 2) Inspect all threads for ease of operation - especially descent valves, brake release valve etc.
- 3) Check level and quantity of oil. Remove any contaminants - water, etc.
- 4) Check batteries for electrolyte and state of charge.
- 5) Check electrics for damage and insulation.

### **Operating & Safety Instructions**

- 6) Using base controls, cycle machine over complete envelope in accordance with the Operating Instructions. Cure any defects.
- 7) Ensure that all safety devices and controls operate in accordance with the instructions.
- 8) If necessary, perform a load test to establish the machine stability before putting the machine to work.
- 9) On completion of an extended period of road transport, the machine might need additional inspection to identify any transit degradation, which could render the machine unsafe. Perform a P.D.I. inspection on the unit before it enters service. Record any faults found and rectify them immediately.
- 10) If left un-attended for an extended period, it is likely that the hydraulic cage levelling will become un-pressurised. Normal operation is then lost, with a noticeable delay in the forwards or backwards motion as the booms move. To restore normal function, the cage needs to be fully levelled forwards and backwards, using the cage-levelling lever whilst not standing in the cage (i.e. with the operator standing adjacent to the cage side whilst simultaneously operating the lever and green button to move the cage). Take care not to become trapped between the moving cage and a fixed object, and ensure those around you are clear of the moving cage. When the system has been charged in both directions, the cage levelling function should be restored. If the system operates but is 'jerky' in either direction, this indicates air in the system. Repeat the procedure as described above until the movements are smooth and un-interrupted. If in doubt, contact our Service Department for further advice.

Niftylift Limited is not liable for any third party damage caused during transport. Careful attention to correct procedures will prevent many of the small snags that can happen in transit. Re-work is both expensive and time consuming. A defective machine arriving at the place of work is a poor advertisement for our product, the company's reputation and those of our dealers and clients. The responsibility for safe and damage-free transport rests with the haulier or his representatives.

## 5 Emergency Controls

### 5.1 GENERAL

**CHECKING THE OPERATION OF THE EMERGENCY CONTROLS EVERY DAY AND/OR BEFORE EACH SHIFT IS AN ESSENTIAL PART OF THE OPERATOR'S DUTIES**



The operator and all ground personnel must be thoroughly familiar with the location and operation of the EMERGENCY CONTROLS.

### 5.2 IN THE EVENT OF AN INCAPACITATED OPERATOR

Turn the key switch selector at ground control station to ground (i.e. fully down). Lower on ground controls as detailed under section 4.3 Ground control operation.

### 5.3 IN THE EVENT OF MACHINE FAILURE

Operate manual hand pump (located adjacent to the base controls) and lower platform to the ground using either platform or base controls. If initial movement of the machine allows the master alarm to reset, normal controls will be available. This is then the fastest method of lowering the platform to the ground.

**Note:** If the machine is fitted with a cage overload system, and the cage comes into contact with a fixed object whilst operating at height, this would be detected as an overload condition. All power to the machine controls would be lost, requiring the machine to be recovered using the **Manual Hand Pump**. It is sufficient for the cage to be manoeuvred away from the collision point to release the cage weigh system, thereby restoring normal machine operation. The cage could then be brought down using the controls as described previously.



**FOLLOWING AN EMERGENCY DESCENT RECOVERY OF THE PLATFORM, FULLY EXTEND AND RETRACT ALL CYLINDERS FROM GROUND CONTROL STATION BEFORE USING THE MACHINE.**

### 5.4 INCIDENT NOTIFICATION

It is a mandatory requirement that any accident or incident involving a Niftylift, regardless of whether any party received injury or property was damaged, be reported by telephone directly to Niftylift. Failure to do so may render any warranty on the machine void.

### 5.5 OUTRIGGER RECOVERY

#### 2 Wheel Drive Models

The Manual Hand pump operates as normal to provide flow into the hydraulic system. As long as the hand pump is being used, hydraulic flow is available. Once the booms are fully stowed, move the diverter valve handle, located at the top of Boom 1, to direct the flow through to the manual outrigger levers. Operate the hand pump whilst holding a lever to retract each outrigger as required.

## **Operating & Safety Instructions**

### **4 Wheel Drive Models**

Hand pump flow is directed by leaving the brake override lever in the 'normal' upright position to direct flow up to the duty selector.

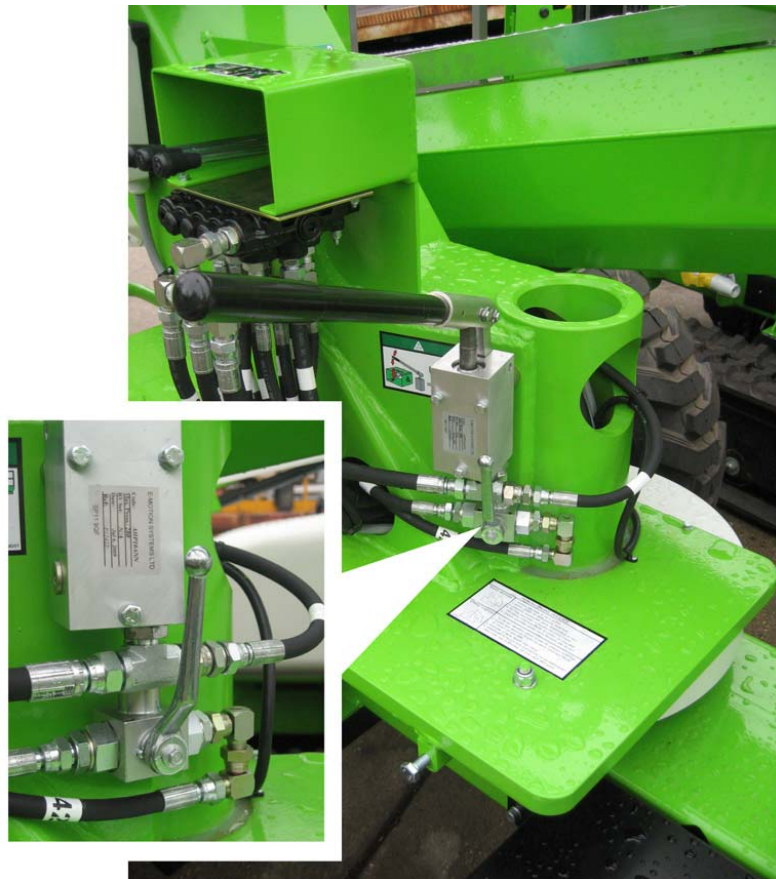

Once the booms are fully stowed, tie-wrap the duty selector in the 'Drive/Outrigger' position (as shown below) and remove the canopies to gain access to the machine hydraulics.





## **nifty** SD Series Operating & Safety Instructions

The handle on the outrigger bypass interlock valve is positioned horizontally (see below) to allow the flow to return to tank. (Normal operation)

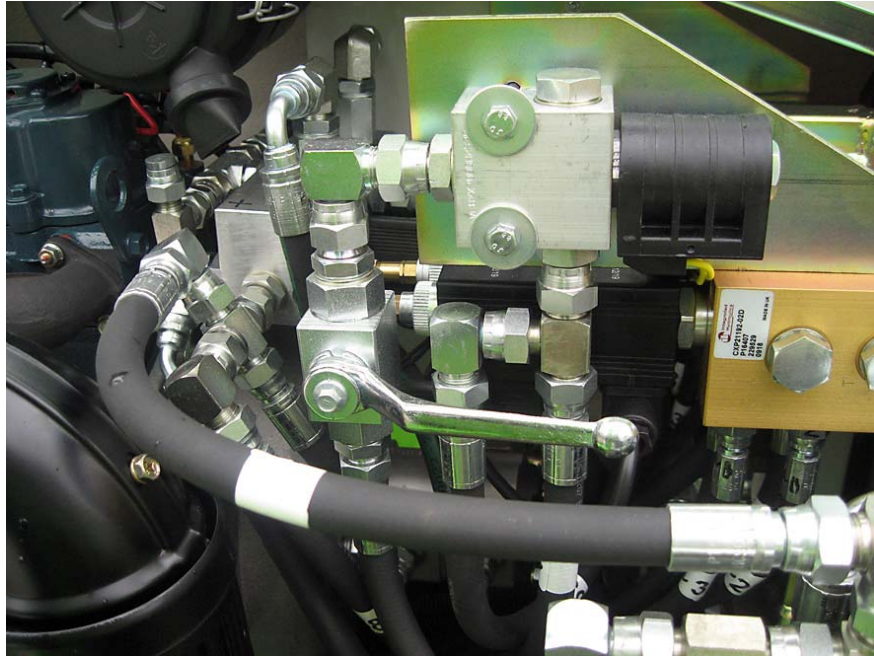

Move the lever **downwards** to block the flow (see below). The Safety Bypass Solenoid is now inoperative.



### **Operating & Safety Instructions**

---

The outrigger solenoid manual overrides can now be used to manually operate the solenoid spools.

To retract an outrigger, the manual override (see below) needs to be **pulled out**, away from the solenoid body. Operate the hand pump and the outrigger will **close**.

If the manual override is **pushed in** toward the solenoid body, operating the hand pump will cause the outrigger **to open/lower**.

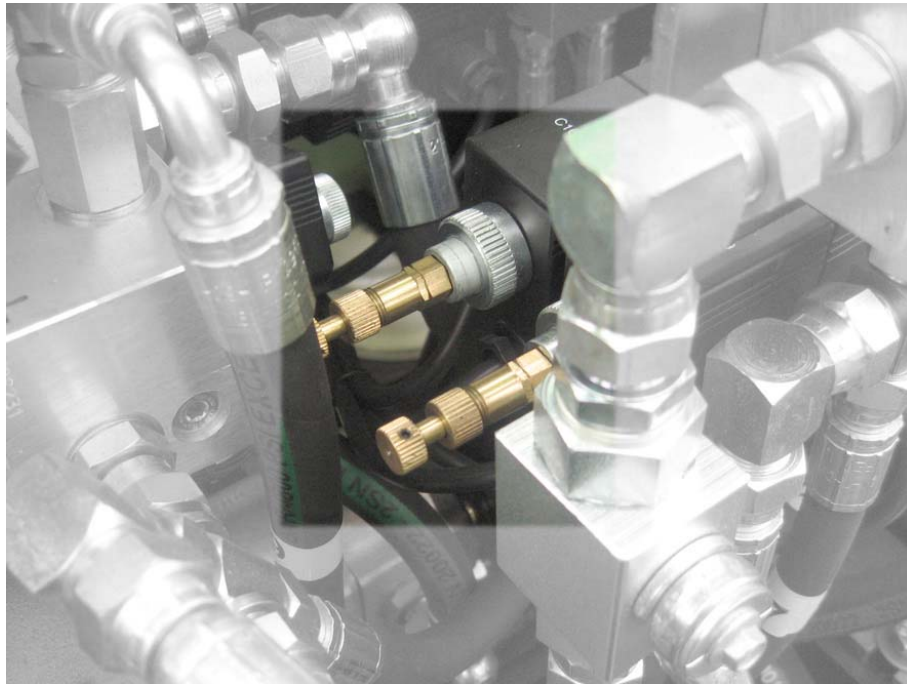

Operate each of the controls in turn; identifying the movement of each outrigger until the machine is fully stowed for recovery.

This method assumes that the hydraulic power from the engine or motors has been lost and that the electrical circuit is also no longer functioning. If the outrigger control system with the toggle switches is still active, they can be used to activate the solenoids to retract each outrigger cylinder, whilst at the same time using the hand pump to power the hydraulics.

Once the machine is ready to return to work, ensure the safety bypass lever is moved back to the 'Normal' horizontal position (refer to page 43) to allow flow back to tank from the bypass solenoid, restoring the safety circuit.

**Remove the tie-wrap on the duty selector handle.**

## **6 Responsibilities**

### **6.1 CHANGES IN OWNERSHIP**

When a change of ownership of a Niftylift occurs, it shall be the responsibility of the seller to notify Niftylift direct of the unit, model and serial number and the name and address of the new owner within 60 days. This important step is required so that all future Technical Bulletins are able to reach the registered owner of each machine without delay. Please note warranties are not transferable.

### **6.2 MANUAL OF RESPONSIBILITIES**

You are required by ANSI/SIA 92.2 1990, to read and understand your responsibilities before you use or operate this aerial platform.

Please read the enclosed document, as failure to do so could result in death or serious injury.

Wherever any contradiction may appear, the Manual of Responsibilities shall take precedence over all other documents.

**Operating & Safety Instructions**

**6.3 INSPECTION/SERVICE/PRE-HIRE CHECK LIST**

**MACHINE SERIAL NO** \_\_\_\_\_

<b>TOWING</b>	<b>PASS</b>	<b>FAIL</b>	<b>N/A</b>
Machine secured on trailer			
Straps correctly positioned and tightened			
Wheels chocked if necessary			
<b>AXLES, WHEELS AND BRAKES</b>			
Wheels are secure, tyre condition acceptable			
Wheel bearings O.K.			
Brake linkages and cables secure			
Brake shoe wear not excessive			
Machine climbs slope			
Brakes hold machine on slope			
Rear hub nut secure			
Track rod secure, not fouling axle plate			
<b>BASE</b>			
Operation of base control valve and buttons			
Operation of all booms over full range			
Wheel bearings OK			
Cylinders are silent			
Cage is level over full range			
Booms, levelling rods not damaged or distorted			
Booms levelling rods, cylinders not fouling			
Hoses not tight, kinked or fouled			
Operation of manual hand pump			
<b>SLEWING</b>			
Slew assembly and motor are secure			
Worm/wheel mesh correct, no excessive wear			
No end float of worm in housing			
Slew wheel bolts secure			
Slew guards secure			
<b>CAGE</b>			
Operation of control valve and buttons			
Levelling lock valve holds in both directions, lines vented			
Operation of all booms over full range			
Cylinders are silent			
Cage levelling over full range			
Slewing smooth over full range			
Operation of boom 4 over full range (if fitted)			
No excessive movement of boom 4 and boom 3			



<b>TILT ALARM</b>	<b>PASS</b>	<b>FAIL</b>	<b>N/A</b>
Booms raised on slope - drive disabled, siren tone constant			
Boom operation unaffected			
Booms lowered - drive restored			
<b>INTERNAL (POWER PACK)</b>			
Power pack and all components secure			
All cables and terminals secure			
All hose connections secure			
Hoses not kinked or fouled			
Charger/control box secure			
Batteries secure			
Electrolyte level and specific gravity			
Charger operation			
Hydraulic oil level			
Engine/Gear box oil			
<b>FINISH</b>			
Pivot pin tag bolts			
Correct decals, all visible			
Canopy/bonnets			
Grease nipples (Feet, Knuckle, Centre Post)			
<b>LEAK CHECK</b>			
Cylinders (Lift, Outriggers, Telescope, Levelling)			
Control valves			
Check valves			
Power pack/pump			
Slew motor			
Hose connections			
Filter			
Wheel motors			

**Comments, remedial work required etc;**

**INSPECTED BY:** \_\_\_\_\_

**DATE:**    /    / **0**